

Incremental Cycle Detection, Topological Ordering, and Strong Component Maintenance

BERNHARD HAEUPLER, Massachusetts Institute of Technology
 TELIKEPALLI KAVITHA, Tata Institute of Fundamental Research
 ROGERS MATHEW, Indian Institute of Science
 SIDDHARTHA SEN, Princeton University
 ROBERT E. TARJAN, Princeton University & HP Laboratories

We present two on-line algorithms for maintaining a topological order of a directed n -vertex acyclic graph as arcs are added, and detecting a cycle when one is created. Our first algorithm handles m arc additions in $O(m^{3/2})$ time. For sparse graphs ($m/n = O(1)$), this bound improves the best previous bound by a logarithmic factor, and is tight to within a constant factor among algorithms satisfying a natural *locality* property. Our second algorithm handles an arbitrary sequence of arc additions in $O(n^{5/2})$ time. For sufficiently dense graphs, this bound improves the best previous bound by a polynomial factor. Our bound may be far from tight: we show that the algorithm can take $\Omega(n^2 2^{\sqrt{2} \lg n})$ time by relating its performance to a generalization of the k -levels problem of combinatorial geometry. A completely different algorithm running in $\Theta(n^2 \log n)$ time was given recently by Bender, Fineman, and Gilbert. We extend both of our algorithms to the maintenance of strong components, without affecting the asymptotic time bounds.

Categories and Subject Descriptors: F.2.2 [Analysis of Algorithms and Problem Complexity]: Nonnumerical Algorithms and Problems—Computations on discrete structures; G.2.2 [Discrete Mathematics]: Graph Theory—Graph algorithms; E.1 [Data]: Data Structures—Graphs and networks

General Terms: Algorithms, Theory

Additional Key Words and Phrases: Dynamic algorithms, directed graphs, topological order, cycle detection, strong components, halving intersection, arrangement

ACM Reference Format:

Haeupler, B., Kavitha, T., Mathew, R., Sen, S., and Tarjan, R. E. 2011. Incremental Cycle Detection, Topological Ordering, and Strong Component Maintenance. *ACM Trans. Algor.* V, N, Article A (January YYYY), 31 pages.
 DOI = 10.1145/0000000.0000000 <http://doi.acm.org/10.1145/0000000.0000000>

A preliminary version of this article appeared in *Proceedings of the 35th International Colloquium on Automata, Languages, and Programming (ICALP), Reykjavik, Iceland, July 7-11, 2008*.

Author's addresses: Bernhard Haeupler, CSAIL, Massachusetts Institute of Technology, Cambridge, MA 02139, United States, haeupler@mit.edu; work done while the author was a visiting student at Princeton University. Telikepalli Kavitha, Tata Institute of Fundamental Research, Mumbai, India, kavitha@tcs.tifr.res.in; work done while the author was at Indian Institute of Science. Rogers Mathew, Indian Institute of Science, Bangalore, India, rogers@csa.iisc.ernet.in. Siddhartha Sen, Department of Computer Science, Princeton University, Princeton, NJ 08540, United States, ssix@cs.princeton.edu. Robert E. Tarjan, Department of Computer Science, Princeton University, Princeton, NJ 08540, United States and HP Laboratories, Palo Alto, CA 94304, United States, ret@cs.princeton.edu.

Research at Princeton University partially supported by NSF grants CCF-0830676 and CCF-0832797. The information contained herein does not necessarily reflect the opinion or policy of the federal government and no official endorsement should be inferred.

Permission to make digital or hard copies of part or all of this work for personal or classroom use is granted without fee provided that copies are not made or distributed for profit or commercial advantage and that copies show this notice on the first page or initial screen of a display along with the full citation. Copyrights for components of this work owned by others than ACM must be honored. Abstracting with credit is permitted. To copy otherwise, to republish, to post on servers, to redistribute to lists, or to use any component of this work in other works requires prior specific permission and/or a fee. Permissions may be requested from Publications Dept., ACM, Inc., 2 Penn Plaza, Suite 701, New York, NY 10121-0701 USA, fax +1 (212) 869-0481, or permissions@acm.org.

© YYYY ACM 1549-6325/YYYY/01-ARTA \$10.00

DOI 10.1145/0000000.0000000 <http://doi.acm.org/10.1145/0000000.0000000>

1. INTRODUCTION

In this paper we consider three related problems on dynamic directed graphs: cycle detection, maintaining a topological order, and maintaining strong components. We begin with a few standard definitions. A *topological order* of a directed graph is a total order “ $<$ ” of the vertices such that for every arc (v, w) , $v < w$. A directed graph is *strongly connected* if every vertex is reachable from every other. The *strongly connected components* of a directed graph are its maximal strongly connected subgraphs. These components partition the vertices [Harary et al. 1965]. Given a directed graph G , its *graph of strong components* is the graph whose vertices are the strong components of G and whose arcs are all pairs (X, Y) with $X \neq Y$ such that there is an arc in the original graph from a vertex in X to a vertex in Y . The graph of strong components is acyclic [Harary et al. 1965].

A directed graph has a topological order (and in general more than one) if and only if it is acyclic. The first implication is equivalent to the statement that every partial order can be embedded in a total order, which, as Knuth [Knuth 1973] noted, was proved by Szpilrajn [Szpilrajn 1930] in 1930, for infinite as well as finite sets. Szpilrajn remarked that this result was already known to at least Banach, Kuratowski, and Tarski, though none of them published a proof.

Given a fixed n -vertex, m -arc graph, one can find either a cycle or a topological order in $O(n+m)$ time by either of two methods: repeated deletion of sources (vertices of in-degree zero) [Knuth 1973; Knuth and Szwarcfter 1974] or depth-first search [Tarjan 1972]. The former method (but not the latter) extends to the enumeration of all possible topological orders [Knuth and Szwarcfter 1974]. One can find strong components, and a topological order of the strong components in the graph of strong components, in $O(n+m)$ time using depth-first search, either one-way [Cheriy and Mehlhorn 1996; Gabow 2000; Tarjan 1972] or two-way [Sharir 1981; Aho et al. 1983].

In some situations the graph is not fixed but changes over time. An *incremental* problem is one in which vertices and arcs can be added; a *decremental* problem is one in which vertices and arcs can be deleted; a *(fully) dynamic* problem is one in which vertices and arcs can be added or deleted. Incremental cycle detection or topological ordering occurs in circuit evaluation [Alpern et al. 1990], pointer analysis [Pearce et al. 2003], management of compilation dependencies [Marchetti-Spaccamela et al. 1993; Omohundro et al. 1992], and deadlock detection [Belik 1990]. In some applications cycles are not fatal; strong components, and possibly a topological order of them, must be maintained. An example is speeding up pointer analysis by finding cyclic relationships [Pearce and Kelly 2003].

We focus on incremental problems. We assume that the vertex set is fixed and given initially, and that the arc set is initially empty. We denote by n the number of vertices and by m the number of arcs added. For simplicity in stating time bounds we assume that $m = \Omega(n)$. We do not allow multiple arcs, so $m \leq \binom{n}{2}$. One can easily extend our algorithms to support vertex additions in $O(1)$ time per vertex addition. (A new vertex has no incident arcs.) Our topological ordering algorithms, as well as all others in the literature, can handle arc deletions as well as insertions, since an arc deletion preserves topological order, but our time bounds are no longer valid. Maintaining strong components as arcs are deleted, or inserted and deleted, is a harder problem, as is maintaining the transitive closure of a directed graph under arc insertions and/or deletions. These problems are quite interesting and much is known, but they are beyond the scope of this paper. We refer the interested reader to Roditty and Zwick [Roditty and Zwick 2008] and the references given there for a thorough discussion of results on these problems.

Our goal is to develop algorithms for incremental cycle detection and topological ordering that are significantly more efficient than running an algorithm for a static graph from scratch after each arc addition. In Section 2 we discuss the use of graph search to solve these problems, work begun by Shmueli [Shmueli 1983] and realized more fully by Marchetti-Spaccamela et al. [Marchetti-Spaccamela et al. 1996], whose algorithm runs in $O(nm)$ time. In Section 3 we develop a two-way search method that we call *compatible search*. Compatible search is essentially a generalization of two-way ordered search, which was first proposed by Alpern et al. [Alpern et al. 1990]. They gave a time bound for their algorithm in an incremental model of computation, but their analysis does

not give a good bound in terms of n and m . They also considered batched arc additions. Katriel and Bodlaender [Katriel and Bodlaender 2006] gave a variant of two-way ordered search with a time bound of $O(\min\{m^{3/2} \log n, m^{3/2} + n^2 \log n\})$. Liu and Chao [Liu and Chao 2007] improved the bound of this variant to $\Theta(m^{3/2} + mn^{1/2} \log n)$, and Kavitha and Mathew [Kavitha and Mathew 2007] gave another variant with a bound of $O(m^{3/2} + nm^{1/2} \log n)$.

A two-way search need not be ordered to solve the topological ordering problem. We apply this insight in Section 4 to develop a version of compatible search that we call *soft-threshold search*. This method uses either median-finding (which can be approximate) or random sampling in place of the heaps (priority queues) needed in ordered search, resulting in a time bound of $O(m^{3/2})$. We also show that any algorithm among a natural class of algorithms takes $\Omega(nm^{1/2})$ time in the worst case. Thus for sparse graphs ($m/n = O(1)$) our bound is best possible in this class of algorithms.

The algorithms discussed in Sections 3 and 4 have two drawbacks. First, they require a sophisticated data structure, namely a *dynamic ordered list* [Bender et al. 2002; Dietz and Sleator 1987], to maintain the topological order. One can address this drawback by maintaining the topological order as an explicit numbering of the vertices from 1 through n . Following Katriel [Katriel 2004], we call an algorithm that does this a *topological sorting* algorithm. The one-way search algorithm of Marchetti-Spaccamela et al. [Marchetti-Spaccamela et al. 1996] is such an algorithm. Pearce and Kelly [Pearce and Kelly 2006] gave a two-way-search topological sorting algorithm. They claimed it is fast in practice, although they did not give a good time bound in terms of n and m . Katriel [Katriel 2004] showed that any topological sorting algorithm that has a natural *locality* property takes $\Omega(n^2)$ time in the worst case even if $m/n = \Theta(1)$.

The second drawback of the algorithms discussed in Sections 3 and 4 is that using graph search to maintain a topological order becomes less and less efficient as the graph becomes denser. Ajwani et al. [Ajwani et al. 2006] addressed this drawback by giving a topological sorting algorithm with a running time of $O(n^{11/4})$. In Section 5 we simplify and improve this algorithm. Our algorithm searches the topological order instead of the graph. We show that it runs in $O(n^{5/2})$ time. This bound may be far from tight. We obtain a lower bound of $\Omega(n2^{\sqrt{2 \lg n}})$ on the running time of the algorithm by relating its efficiency to a generalization of the k -levels problem of combinatorial geometry.

In Section 6 we extend the algorithms of Sections 4 and 5 to the incremental maintenance of strong components. We conclude in Section 7 with some remarks and open problems.

This paper is an improvement and extension of a conference paper [Haeupler et al. 2008], which itself is a combination and condensation of two on-line reports [Haeupler et al. 2008; Kavitha and Mathew 2007]. Our main improvement is a simpler analysis of the algorithm presented in Section 5 and originally in [Kavitha and Mathew 2007]. At about the same time as [Kavitha and Mathew 2007] appeared and also building on the work of Ajwani et al., Liu and Chao [Liu and Chao 2008] independently obtained a topological sorting algorithm that runs in $O(n^{5/2} \log^2 n)$ or $O(n^{5/2} \log n)$ time, depending on the details of the implementation. More recently, Bender, Fine-man, and Gilbert [Bender et al. 2009] have presented a topological ordering algorithm that uses completely different techniques and runs in $\Theta(n^2 \log n)$ time.

2. ONE-WAY SEARCH

The simplest of the three problems we study is that of detecting a cycle when an arc addition creates one. All the known efficient algorithms for this problem, including ours, rely on the maintenance of a topological order. When an arc (v, w) is added, we can test for a cycle by doing a search forward from w until either reaching v (there is a cycle) or visiting all vertices reachable from w without finding v . This method takes $\Theta(m)$ time per arc addition in the worst case, for a total of $\Theta(m^2)$ time. By maintaining a topological order, we can improve this method. When a new arc (v, w) is added, test if $v < w$. If so, the order is still topological, and the graph is acyclic. If not, search for v from w . If the search finishes without finding v , we need to restore topological order, since (at least)

```

arc function LIMITED-SEARCH(vertex  $v$ , vertex  $w$ )
   $F = \{w\}$ ;  $A = \{(w, x) \mid (w, x) \text{ is an arc}\}$ 
  while  $A \neq \{\}$  do
    choose  $(x, y) \in A$ ;  $A = A - \{(x, y)\}$ 
    if  $y = v$  then return  $(x, y)$ 
    else if  $y < v$  and  $y \notin F$  then
       $F = F \cup \{y\}$ ;  $A = A \cup \{(y, z) \mid (y, z) \text{ is an arc}\}$ 
    end
  end
  return null

```

Fig. 1. Implementation of limited search.

v and w are out of order. We can make the order topological by moving all the vertices visited by the search to positions after all the other vertices, and ordering the visited vertices among themselves topologically.

We need a way to represent the topological order. A simple numbering scheme suffices. Initially, number the vertices arbitrarily from 1 through n and initialize a global counter c to n . When a search occurs, renumber the vertices visited by the search consecutively from $c + 1$, in a topological order with respect to the subgraph induced by the set of visited vertices, and increment c to be the new maximum vertex number. One way to order the visited vertices is to make the search depth-first and order the vertices in reverse postorder [Tarjan 1972]. With this scheme, all vertex numbers are positive integers no greater than nm .

Shmueli [Shmueli 1983] proposed this method as a heuristic for cycle detection, although he used a more-complicated two-part numbering scheme and he did not mention that the method maintains a topological order. In the worst case, every new arc can invalidate the current topological order and trigger a search that visits a large part of the graph, so the method does not improve the $O(m^2)$ worst-case bound for cycle detection. But it is the starting point for asymptotic improvement.

To do better we use the topological order to limit the searching. The search for v from w need not visit vertices larger than v in the current order, since no such vertex, nor any vertex reachable from such a vertex, can be v . Here is the resulting method in detail. When a new arc (v, w) has $v > w$, search for v from w by calling LIMITED-SEARCH(v, w), where the function LIMITED-SEARCH is defined in Figure 1. In this and later functions and procedures, a minus sign denotes set subtraction.

In LIMITED-SEARCH, F is the set of vertices visited by the search, and A is the set of arcs to be traversed by the search. An iteration of the while loop that deletes an arc (x, y) from A does a *traversal* of (x, y) . The choice of which arc in A to traverse is arbitrary. If the addition of (v, w) creates a cycle, LIMITED-SEARCH(v, w) returns an arc $(x, y) \neq (v, w)$ on such a cycle; otherwise, it returns null. If it returns null, restore topological order by moving all vertices in F just after v (and before the first vertex following v , if any). Order the vertices within F topologically, for example by making the search depth-first and ordering the vertices in F in reverse postorder with respect to the search. Figure 2 shows an example of limited search and reordering.

Before discussing how to implement the reordering, we bound the total time for the limited searches. If we represent F and A as linked lists and mark vertices as they are added to F , the time for a search is $O(1)$ plus $O(1)$ per arc traversal. Only the last search, which does at most m arc traversals, can report a cycle. To bound the total number of arc traversals, we introduce the notion of *relatedness*. We define a vertex and an arc to be *related* if some path contains both the vertex and the arc, and *unrelated* otherwise. This definition does not depend on whether the vertex or the arc occurs first on the path; they are related in either case. If the graph is acyclic, only one order is possible, but in a cyclic graph, a vertex can occur before an arc on one path and after the arc on a different path. If either case occurs, or both, the vertex and the arc are related.

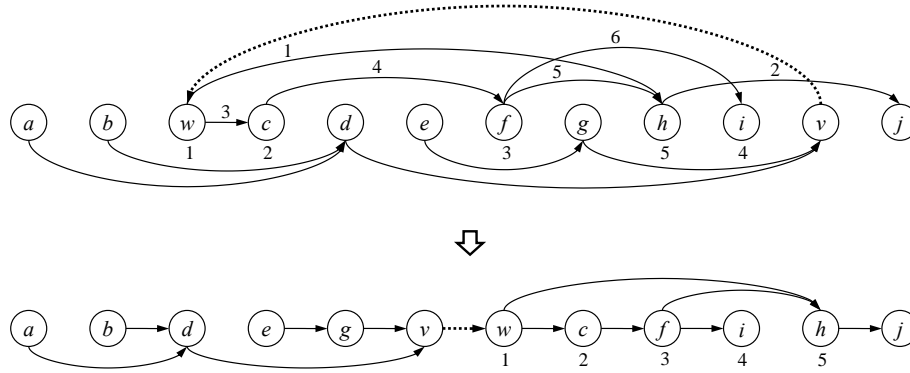

Fig. 2. Limited search followed by vertex reordering. Initial topological order is left-to-right. Arcs are numbered in order of traversal; the search is depth-first. Visited vertices are w, c, f, h, i, j . They are numbered in reverse postorder with respect to the search and reordered correspondingly.

LEMMA 2.1. *Suppose the addition of (v, w) does not create a cycle but does trigger a search. Let (x, y) be an arc traversed during the (unsuccessful) search for v from w . Then v and (x, y) are unrelated before the addition but related after it.*

PROOF. Let $<$ be the topological order before the addition of (v, w) . Since $x < v$, for v and (x, y) to be related before the addition there must be a path containing (x, y) followed by v . But then there is a path from x to v . Since there is a path from w to x , the addition of (v, w) creates a cycle, a contradiction. Thus v and (x, y) are unrelated before the addition. After the addition there is a path from v through (v, w) to (x, y) , so v and (x, y) are related. \square

The number of related vertex-arc pairs is at most nm , so the number of arc traversals during all limited searches, including the last one, is at most $nm + m$. Thus the total search time is $O(nm)$.

Shmueli [Shmueli 1983] suggested this method but did not analyze it. Nor did he give an efficient way to do the reordering; he merely hinted that one could modify his numbering scheme to accomplish this. According to Shmueli, “This may force us to use real numbers (not a major problem).” In fact, it *is* a major problem, because the precision required may be unrealistically high.

To do the reordering efficiently, we need a representation more complicated than a simple numbering scheme. We use instead a solution to the *dynamic ordered list* problem: represent a list of distinct elements so that order queries (does x occur before y in the list?), deletions, and insertions (insert a given non-list element just before, or just after, a given list element) are fast. Solving this problem is tantamount to addressing the precision question that Shmueli overlooked. Dietz and Sleator [Dietz and Sleator 1987] gave two related solutions. Each takes $O(1)$ time worst-case for an order query or a deletion. For an insertion, the first takes $O(1)$ amortized time; the second, $O(1)$ time worst-case. Bender et al. [Bender et al. 2002] simplified the Dietz-Sleator methods. With any of these methods, the time for reordering after an arc addition is bounded by a constant factor times the search time, so m arc additions take $O(nm)$ time.

There is a simpler way to do the reordering, but it requires rearranging all *affected vertices*, those between w and v in the order (inclusive): move all vertices visited by the search after all other affected vertices, preserving the original order within each of these two sets. Figure 3 illustrates this alternative reordering method. We call a topological ordering algorithm *local* if it reorders only affected vertices. Except for Shmueli’s unlimited search algorithm and the recent algorithm of Bender et al. [Bender et al. 2009], all the algorithms we discuss are local.

We can do this reordering efficiently even if the topological order is explicitly represented by a one-to-one mapping between the vertices and the integers from 1 through n . This makes the method

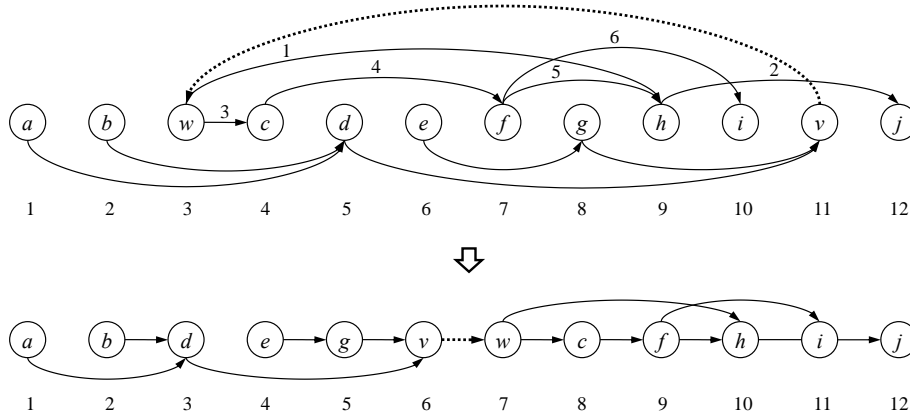

Fig. 3. Alternative method of restoring topological order after a limited search of the graph in Figure 2. The vertices are numbered in topological order. The affected vertices are $w, c, d, e, f, g, h, i, v$. Arcs are numbered in order of traversal. The affected vertices are reordered by moving the visited vertices w, c, f, h, i after the unvisited vertices d, e, g, v .

a topological sorting algorithm as defined in Section 1. This method was proposed and analyzed by Marchetti-Spaccamela et al. [Marchetti-Spaccamela et al. 1996]. The reordering time is $O(n)$ per arc addition; the total time for m arc additions is $O(nm)$.

3. TWO-WAY SEARCH

We can further improve cycle detection and topological ordering by making the search two-way instead of one-way: when a new arc (v, w) has $v > w$, concurrently search forward from w and backward from v until some vertex is reached from both directions (there is a cycle), or enough arcs are traversed to guarantee that the graph remains acyclic; if so, rearrange the visited vertices to restore topological order.

Each step of the two-way search traverses one arc (u, x) forward and one arc (y, z) backward. To make the search efficient, we make sure that these arcs are *compatible*, by which we mean that $u < z$ (in the topological order before (v, w) is added). Here is the resulting method in detail. For ease of notation we adopt the convention that the minimum of an empty set is bigger than any other value and the maximum of an empty set is smaller than any other value. Every vertex is in one of three states: *unvisited*, *forward* (first visited by the forward search), or *backward* (first visited by the backward search). Before any arcs are added, all vertices are unvisited. The search maintains the set F of forward vertices and the set B of backward vertices: if the search does not detect a cycle, certain vertices in $B \cup F$ must be reordered to restore topological order. The search also maintains the set A_F of arcs to be traversed forward and the set A_B of arcs to be traversed backward. If the search detects a cycle, it returns an arc other than (v, w) on the cycle; if there is no cycle, the search returns null.

When a new arc (v, w) has $v > w$, search forward from w and backward from v by calling $\text{COMPATIBLE-SEARCH}(v, w)$, where the function COMPATIBLE-SEARCH is defined in Figure 4.

In compatible search, an iteration of the while loop is a *search step*. The step does a *forward traversal* of the arc (u, x) that it deletes from A_F and a *backward traversal* of the arc (y, z) that it deletes from A_B . The choice of which pair of arcs to traverse is arbitrary, as long as they are compatible. If the addition of (v, w) creates a cycle, it is possible for a single arc (u, z) to be added to both A_F (when u becomes forward) and to A_B (when z becomes backward). It is even possible for such an arc to be traversed both forward and backward in the same search step, but if this happens it is the last search step. Such a double traversal does not affect the correctness of the algorithm. Unlike limited search, compatible search can visit unaffected vertices (those less than w

```

arc function COMPATIBLE-SEARCH(vertex  $v$ , vertex  $w$ )
   $F = \{w\}$ ;  $B = \{v\}$ ;  $A_F = \{(w, x) | (w, x) \text{ is an arc}\}$ ;  $A_B = \{(y, v) | (y, v) \text{ is an arc}\}$ 
  while  $\exists(u, x) \in A_F, \exists(y, z) \in A_B (u < z)$  do
    choose  $(u, x) \in A_F$  and  $(y, z) \in A_B$  with  $u < z$ 
     $A_F = A_F - \{(u, x)\}$ ;  $A_B = A_B - \{(y, z)\}$ 
    if  $x \in B$  then return  $(u, x)$  else if  $y \in F$  then return  $(y, z)$ 
    if  $x \notin F$  then
       $F = F \cup \{x\}$ ;  $A_F = A_F \cup \{(x, q) | (x, q) \text{ is an arc}\}$ 
    end
    if  $y \notin B$  then
       $B = B \cup \{y\}$ ;  $A_B = A_B \cup \{(r, y) | (r, y) \text{ is an arc}\}$ 
    end
  end
  return null

```

Fig. 4. Implementation of compatible search.

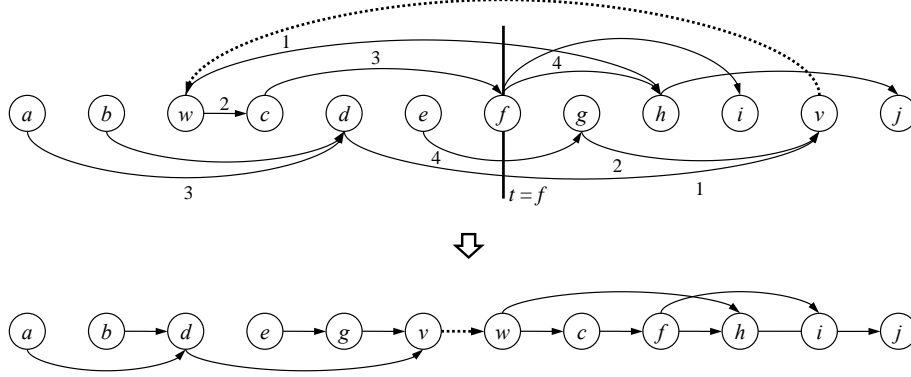

Fig. 5. Compatible search of the graph in Figure 2 and restoration of topological order. Traversed arc pairs are numbered in order of traversal. Forward vertices are w, c, f, h, i ; backward vertices are v, d, g, e, a . After the search, $A_F = \{(f, i), (h, j)\}$; $t = f$; $F_{<} = \{w, c\}$; $B_{>} = \{v, g\}$. Reordering moves vertices in $F_{<}$ just before t and all vertices in $B_{>}$ just before those in $F_{<}$, arranging each internally in topological order.

or greater than v in topological order), but this does not affect correctness, only efficiency. If the search returns null, restore topological order as follows. Let $t = \min(\{v\} \cup \{u | \exists(u, x) \in A_F\})$. Let $F_{<} = \{x \in F | x < t\}$ and $B_{>} = \{y \in B | y > t\}$. If $t = v$, reorder as in limited search (Section 2): move all vertices in $F_{<}$ just after t . (In this case $B_{>} = \{\}$.) Otherwise ($t < v$), move all vertices in $F_{<}$ just before t and all vertices in $B_{>}$ just before all vertices in $F_{<}$. In either case, order the vertices within $F_{<}$ and within $B_{>}$ topologically. Figure 5 illustrates compatible search and reordering.

THEOREM 3.1. *Compatible search correctly detects cycles and maintains a topological order.*

PROOF. The algorithm maintains the invariant that every forward vertex is reachable from w and v is reachable from every backward vertex. Thus if (u, x) with $x \in B$ is traversed forward, there is a cycle consisting of a path from w to u , the arc (u, x) , a path from x to v , and the arc (v, w) . Symmetrically, if (y, z) with $y \in F$ is traversed backward, there is a cycle. Thus if the algorithm reports a cycle, there is one.

Suppose the addition of (v, w) creates a cycle. Such a cycle consists of a pre-existing path P from w to v and the arc (v, w) . The existence of P implies that $v > w$, so the addition of (v, w) will trigger a search. The search maintains the invariant that either there are distinct arcs (u, x) and

(y, z) on P with $x \leq y$, (u, x) is in A_F , and (y, z) is in A_B , or there is an arc (u, z) in both A_F and A_B . In either case there is a compatible arc pair, so the search can only stop by returning a non-null arc. Thus if there is a cycle the algorithm will report one.

It remains to show that if $v > w$ and the addition of (v, w) does not create a cycle, then the algorithm restores topological order. This is a case analysis. First consider (v, w) . If $t = v$, then w is in $F_<$. If $t < v$, then v is in $B_>$ and w is in $\{t\} \cup F_<$. In either case, v precedes w after the reordering.

Second, consider an arc (x, y) other than (v, w) . Before the reordering $x < y$; we must show that the reordering does not reverse this order. There are five cases:

Case 1: neither x nor y is in $F_< \cup B_>$. Neither x nor y is reordered.

Case 2: x is in $F_<$. Vertex y must be forward. If $y < t$ then y is in $F_<$, and the order of x and y is preserved because the reordering within $F_<$ is topological. If $y = t$, then $t < v$, so the reordering inserts x before $t = y$. If $y > t$, the reordering does not move y and inserts x before y .

Case 3: y is in $F_<$ but x is not. Vertex x is not moved, and y follows x after the reordering since vertices in $F_<$ are only moved higher in the order.

Case 4: y is in $B_>$. Vertex x must be backward. Then $x \neq t$, since $x = t$ would imply $t = v$ (since x is backward) and $y > v$, which is impossible. If $x > t$ then x is in $B_>$, and the order of x and y is preserved because the reordering within $B_>$ is topological. If $x < t$, the reordering does not move x and inserts y after x .

Case 5: x is in $B_>$ but y is not. Vertex y is not moved, and y follows x after the reordering since vertices in $B_>$ are only moved lower in the order.

We conclude that the reordering restores topological order. \square

A number of implementation details remain to be filled in. Before doing this, we prove the key result that bounds the efficiency of two-way compatible search: the total number of arc traversals over m arc additions is $O(m^{3/2})$. To prove this, we extend the notion of relatedness used in Section 2 to arc pairs: two distinct arcs are *related* if they are on a common path. Relatedness is symmetric: the order in which the arcs occur on the common path is irrelevant. (In an acyclic graph only one order is possible, but in a graph with cycles both orders can occur, on different paths.) The following lemma is analogous to Lemma 2.1:

LEMMA 3.2. *Suppose the addition of (v, w) triggers a search but does not create a cycle. Let (u, x) and (y, z) , respectively, be compatible arcs traversed forward and backward during the search, not necessarily during the same search step. Then (u, x) and (y, z) are unrelated before the addition of (v, w) but are related after the addition.*

PROOF. Since adding (v, w) does not create a cycle, (u, x) and (y, z) must be distinct. Suppose (u, x) and (y, z) were related before the addition of (v, w) . Let P be a path containing both. The definition of compatibility is $u < z$. But $u < z$ implies that (u, x) precedes (y, z) on P . Since u is forward and z is backward, the addition of (v, w) creates a cycle, consisting of a path from w to u , the part of P from u to z , a path from z to v , and the arc (v, w) . This contradicts the hypothesis of the lemma. Thus (u, x) and (y, z) are unrelated before the addition of (v, w) .

After the addition of (v, w) , there is a path containing both (u, x) and (y, z) , consisting of (y, z) , a path from z to v , the arc (v, w) , a path from w to u , and the arc (u, x) . Thus (u, x) and (y, z) are related after the addition. \square

THEOREM 3.3. *Over m arc additions, two-way compatible search does at most $4m^{3/2} + m + 1$ arc traversals.*

PROOF. Only the last arc addition can create a cycle; the corresponding search does at most $m + 1$ arc traversals. (One arc may be traversed twice.) Consider any search other than the last. Let A be the set of arcs traversed forward during the search. Let k be the number of arcs in A . Each arc (u, x) in A has a distinct *twin* (y, z) that was traversed backward during the search step that traversed (u, x) . These twins are compatible; that is, $u < z$. Order the arcs (u, x) in A in non-decreasing order

on u . Each arc (u, x) in A is compatible not only with its own twin but also with the twin of each arc (q, r) following (u, x) in the order within A , because if (y, z) is the twin of (q, r) , $u \leq q < z$. Thus if (u, x) is i^{th} in the order within A , (u, x) is compatible with at least $k - i + 1$ twins of arcs in A . By Lemma 3.2, each such compatible pair is unrelated before the addition of (v, w) but is related after the addition. Summing over all arcs in A , we find that the addition of (v, w) increases the number of related arc pairs by at least $k(k + 1)/2$.

Call a search other than the last one *small* if it does no more than $2m^{1/2}$ arc traversals and *big* otherwise. Since there are at most m small searches, together they do at most $2m^{3/2}$ arc traversals. A big search that does $2k$ arc traversals is triggered by an arc addition that increases the number of related arc pairs by at least $k(k + 1)/2 > km^{1/2}/2$. Since there are at most $\binom{m}{2} < m^2/2$ related arc pairs, the total number of arc traversals during big searches is at most $2m^{3/2}$. \square

The example in Figure 5 illustrates the argument in the proof of Theorem 3.3. The arcs traversed forward, arranged in non-decreasing order by first vertex, are (w, h) with twin (d, v) , (w, c) with twin (g, v) , (c, f) with twin (a, d) , and (f, h) with twin (e, g) . Arc (w, h) is compatible with the twins of all arcs in A , (w, c) is compatible with its own twin and those of (c, f) and (f, h) , (c, f) is compatible with its own twin and that of (f, h) , and (f, h) is compatible with its own twin. There can be other compatible pairs, and indeed there are in this example, but the proof does not use them.

Our goal now is to implement two-way compatible search so that the time per arc addition is $O(1)$ plus $O(1)$ per arc traversal. By Theorem 3.3, this would give a time bound of $O(m^{3/2})$ for m arc additions. First we discuss the graph representation, then the maintenance of the topological order, and finally (in this and the next section) the detailed implementation of the search algorithm.

We represent the graph using forward and backward incidence lists: each vertex has a list of its outgoing arcs and a list of its incoming arcs, which we call the *outgoing list* and *incoming list*, respectively. Singly linked lists suffice. We denote by $first-out(x)$ and $first-in(x)$ the first arc on the outgoing list and the first arc on the incoming list of vertex x , respectively. We denote by $next-out((x, y))$ and $next-in((x, y))$ the arcs after (x, y) on the outgoing list of x and the incoming list of y , respectively. In each case, if there is no such arc, the value is null. Adding a new arc (v, w) to this representation takes $O(1)$ time. If the addition of an arc (v, w) triggers a search, we can update the graph representation either before or after the search: arc (v, w) will never be added to either A_F or A_B .

We represent the topological order by a dynamic ordered list. (See Section 2.) If adding (v, w) leaves the graph acyclic but triggers a search, we reorder the vertices after the search as follows. Determine t . Determine the sets $F_<$ and $B_>$. Determine the subgraphs induced by the vertices in $F_<$ and $B_>$. Topologically sort these subgraphs using either of the two linear-time static methods (repeated deletion of sources or depth-first search). Move the vertices in $F_<$ and $B_>$ to their new positions using dynamic ordered list deletions and insertions. The number of vertices in $F \cup B$ is at most two plus the number of arcs traversed by the search. Furthermore, all arcs out of $F_<$ and all arcs into $B_>$ are traversed by the search. It follows that the time for the topological sort and reordering is at most linear in one plus the number of arcs traversed, not including the time to determine t . We discuss how to determine t after presenting some of the details of the search implementation.

We want the time of a search to be $O(1)$ plus $O(1)$ per arc traversal. There are three tasks that are hard to implement in $O(1)$ time: (1) adding arcs to A_F and A_B (the number of arcs added as the result of an arc traversal may not be $O(1)$), (2) testing whether to continue the search, and (3) finding a compatible pair of arcs to traverse.

By making the search vertex-guided instead of arc-guided, we simplify all of these tasks, as well as the determination of t . We do not maintain A_F and A_B explicitly. Instead we partition F and B into *live* and *dead* vertices. A vertex in F is live if it has at least one outgoing untraversed arc; a vertex in B is live if it has at least one incoming untraversed arc; all vertices in $F \cup B$ that are not live are dead. For each vertex x in F we maintain a *forward pointer* $out(x)$ to the first untraversed arc on its outgoing list, and for each vertex y in B we maintain a *backward pointer*

```

arc function VERTEX-GUIDED-SEARCH(vertex  $v$ , vertex  $w$ )
   $F = \{w\}; B = \{v\}; out(w) = first-out(w); in(v) = first-in(v)$ 
  if  $out(w) = null$  then  $F_L = \{\}$  else  $F_L = \{w\}$ 
  if  $in(v) = null$  then  $B_L = \{\}$  else  $B_L = \{v\}$ 
  while  $\min F_L < \max B_L$  do
    choose  $u \in F_L$  and  $z \in B_L$  with  $u < z$ ; SEARCH-STEP( $u, z$ )
  end
  return null

```

Fig. 6. Implementation of vertex-guided search.

```

macro SEARCH-STEP(vertex  $u$ , vertex  $z$ )
   $(u, x) = out(u); (y, z) = in(z)$ 
   $out(u) = next-out((u, x)); in(z) = next-in((y, z))$ 
  if  $out(u) = null$  then  $F_L = F_L - \{u\}$ ; if  $in(z) = null$  then  $B_L = B_L - \{z\}$ 
  if  $x \in B$  then return ( $u, x$ ) else if  $y \in F$  then return ( $y, z$ )
  if  $x \notin F$  then
     $F = F \cup \{x\}; out(x) = first-out(x)$ 
    if  $out(x) \neq null$  then  $F_L = F_L \cup \{x\}$ 
  end
  if  $y \notin B$  then
     $B = B \cup \{y\}; in(y) = first-in(y)$ 
    if  $in(y) \neq null$  then  $B_L = B_L \cup \{y\}$ 
  end

```

Fig. 7. Implementation of a search step.

$in(y)$ to the first untraversed arc on its incoming list; each such pointer is null if there are no untraversed arcs. We also maintain the sets F_L and B_L of live vertices in F and B , respectively. When choosing arcs to traverse, we always choose a forward arc indicated by a forward pointer and a backward arc indicated by a backward pointer. The test whether to continue the search becomes “ $\min F_L < \max B_L$.”

When a new arc (v, w) has $v > w$, do the search by calling VERTEX-GUIDED-SEARCH(v, w), where the function VERTEX-GUIDED-SEARCH is defined in Figure 6. It uses an auxiliary macro SEARCH-STEP, defined in Figure 7, intended to be expanded in-line; each return from SEARCH-STEP returns from VERTEX-GUIDED-SEARCH as well. If VERTEX-GUIDED-SEARCH(v, w) returns null, let $t = \min(\{v\} \cup \{x \in F \mid out(x) \neq null\})$ and reorder the vertices in $F_{<}$ and $B_{>}$ as discussed above.

If we represent F and B by singly linked lists and F_L and B_L by doubly linked lists (so that deletion takes $O(1)$ time), plus flag bits for each vertex indicating whether it is in F and/or B , then the time for a search step is $O(1)$. The time to determine t and to reorder the vertices is at most $O(1)$ plus $O(1)$ per arc traversal.

It remains to implement tasks (2) and (3): testing whether to continue the search and finding a compatible pair of arcs to traverse. In vertex-guided search these tasks are related: it suffices to test whether $\min F_L < \max B_L$; and, if so, to find $u \in F_L$ and $z \in B_L$ with $u < z$. The historical solution is to store F_L and B_L in heaps (priority queues), F_L in a min-heap and B_L in a max-heap, and in each iteration of the while loop to choose $u = \min F_L$ and $z = \max B_L$. This guarantees that $u < z$, since otherwise the continuation test for the search would have failed. With an appropriate heap implementation, the test $\min F_L < \max B_L$ takes $O(1)$ time, as does choosing u and z . Each insertion into a heap takes $O(1)$ time as well, but each deletion from a heap takes $O(\log n)$ time, resulting in an $O(\log n)$ time bound per search step and an $O(m^{3/2} \log n)$ time bound for m arc additions.

This method is in essence the algorithm of Alpern et al. [Alpern et al. 1990], although their algorithm does not strictly alternate forward and backward arc traversals, and they did not obtain a good total time bound. Using heaps but relaxing the alternation of forward and backward arc traversals gives methods with slightly better time bounds [Alpern et al. 1990; Katriel and Bodlaender 2006; Kavitha and Mathew 2007], the best bound to date being $O(m^{3/2} + nm^{1/2} \log n)$ [Kavitha and Mathew 2007]. One can further reduce the running time by using a faster heap implementation, such as those of van Emde Boas [van Emde Boas 1977; van Emde Boas et al. 1977], Thorup [Thorup 2004], and Han and Thorup [Han and Thorup 2002]. Our goal is more ambitious: to reduce the overall running time to $O(m^{3/2})$ by eliminating the use of heaps. This we do in the next section.

4. SOFT-THRESHOLD SEARCH

To obtain a faster implementation of vertex-guided search, we exploit the flexibility inherent in the algorithm by using a *soft threshold* s to help choose u and z in each search step. Vertex s is a forward or backward vertex, initially v . We partition the sets F_L and B_L into *active* and *passive* vertices. Active vertices are candidates for the current search step, passive vertices are candidates for future search steps. We maintain the sets F_A and F_P , and B_A and B_P , of active and passive vertices in F_L and B_L , respectively. All vertices in F_P are greater than s ; all vertices in B_P are less than s ; vertices in $F_A \cup B_A$ can be on either side of s . Searching continues while $F_A \neq \{\}$ and $B_A \neq \{\}$. The algorithm chooses u from F_A and z from B_A arbitrarily. If $u < z$, the algorithm traverses an arc out of u and an arc into z and makes each newly live vertex active. If $u > z$, the algorithm traverses no arcs. Instead, it makes u passive if $u > s$ and makes z passive if $z < s$; $u > z$ implies that at least one of u and z becomes passive. When F_A or B_A becomes empty, the algorithm updates s and the vertex partitions, as follows. Suppose F_A is empty; the updating is symmetric if B_A is empty. The algorithm makes all vertices in B_P dead, makes s dead if it is live, chooses a new s from F_P , and makes active all vertices $x \in F_P$ such that $x \leq s$.

Here are the details of this method, which we call *soft-threshold search*. When a new arc (v, w) has $v > w$, do the search by calling $\text{SOFT-THRESHOLD-SEARCH}(v, w)$, where the function $\text{SOFT-THRESHOLD-SEARCH}$ is defined in Figure 8, and procedure SEARCH-STEP is defined as in Figure 7, but with F_A and B_A replacing F_L and B_L , respectively. If $\text{SOFT-THRESHOLD-SEARCH}(v, w)$ returns null, let $t = \min(\{v\} \cup \{x \in F \mid \text{out}(x) \neq \text{null}\})$ and reorder the vertices in $F_{<}$ and $B_{>}$ as discussed above. Figure 9 illustrates soft-threshold search.

Soft-threshold search is an implementation of vertex-guided search except that it makes additional vertices dead, not just those with no incident arcs left to traverse. Once dead, a vertex stays dead. We need to prove that this does not affect the search outcome. First we prove that soft-threshold search terminates.

THEOREM 4.1. *A soft-threshold search terminates after at most $n^2 + m + n$ iterations of the while loop.*

PROOF. Each iteration either traverses one or two arcs or makes one or two vertices passive. The number of times a vertex can become passive is at most the number of times it becomes active. Vertices become active only when they are visited (once per vertex) or when s changes. Each time s changes, the old s becomes dead if it was not dead already. Thus s changes at most n times. The number of times vertices become active is thus at most $n + n^2$ (once per vertex visit plus once per vertex per change in s). \square

To prove correctness, we need two lemmas.

LEMMA 4.2. *If x is a passive vertex, $x > s$ if x is in F_P , $x < s$ if x is in B_P .*

PROOF. If x is a passive vertex, x satisfies the lemma when it becomes passive, and it continues to satisfy the lemma until s changes. Suppose x is forward; the argument is symmetric if x is backward. If s changes because F_A is empty, x becomes active unless it is greater than the new s . If

```

arc function SOFT-THRESHOLD-SEARCH(vertex  $v$ , vertex  $w$ )
   $F = \{w\}$ ;  $B = \{v\}$ ;  $out(w) = first-out(w)$ ;  $in(v) = first-in(v)$ ;  $s = v$ 
  if  $out(w) = null$  then  $F_A = \{\}$  else  $F_A = \{w\}$ ;  $F_P = \{\}$ 
  if  $in(v) = null$  then  $B_A = \{\}$  else  $B_A = \{v\}$ ;  $B_P = \{\}$ 
  while  $F_A \neq \{\}$  and  $B_A \neq \{\}$  do
    choose  $u \in F_A$  and  $z \in B_A$ 
    if  $u < z$  then SEARCH-STEP( $u, z$ ) else
      if  $u > s$  then
         $F_A = F_A - \{u\}$ ;  $F_P = F_P \cup \{u\}$ 
      end
      if  $z < s$  then
         $B_A = B_A - \{z\}$ ;  $B_P = B_P \cup \{z\}$ 
      end
    end
    if  $F_A = \{\}$  then
       $B_P = \{\}$ ;  $B_A = B_A - \{s\}$ 
      if  $F_P \neq \{\}$  then
        choose  $s \in F_P$ ;  $F_A = \{x \in F_P \mid x \leq s\}$ ;  $F_P = F_P - F_A$ 
      end
    end
    if  $B_A = \{\}$  then
       $F_P = \{\}$ ;  $F_A = F_A - \{s\}$ 
      if  $B_P \neq \{\}$  then
        choose  $s \in B_P$ ;  $B_A = \{x \in B_P \mid x \geq s\}$ ;  $B_P = B_P - B_A$ 
      end
    end
  end
  return null

```

Fig. 8. Implementation of soft-threshold search.

s changes because B_A is empty, x becomes dead. The lemma follows by induction on the number of search steps. \square

LEMMA 4.3. *Let A_F be the set of untraversed arcs out of vertices in F , let A_B be the set of untraversed arcs into vertices in B , let $q = \min\{u \mid \exists (u, x) \in A_F\}$, and let $r = \max\{z \mid \exists (y, z) \in A_B\}$. Then q and r remain live vertices until $q > r$.*

PROOF. If q and r remain live vertices until $q = \infty$ or $r = -\infty$, the lemma holds. Thus suppose q dies before r and before either $q = \infty$ or $r = -\infty$. When q dies, $q = s$ or q is passive, and $B_A = \{\}$. Since r is still live, r is passive. By Lemma 4.2, $q \geq s > r$. The argument is symmetric if r dies before q and before either $q = \infty$ or $r = -\infty$. \square

THEOREM 4.4. *Soft-threshold search is correct.*

PROOF. Let q and r be defined as in Lemma 4.3. By that lemma, the search will continue until a cycle is detected or $q > r$. While the search continues, it traverses arcs in exactly the same way as vertex-guided search. Once $q > r$, the continuation test for vertex-guided search fails. If the graph is still acyclic, the continuation test for soft-threshold search may not fail immediately, but no additional arcs can be traversed; any additional iterations of the while loop merely change the state (active, passive, or dead) of various vertices. Such changes do not affect the outcome of the search. \square

To implement soft-threshold search, we maintain F_A , F_P , B_A , and B_P as doubly-linked lists. The time per search step is $O(1)$, not counting the computations associated with a change in s (the two code blocks at the end of the while loop that are executed if F_A or B_A is empty, respectively).

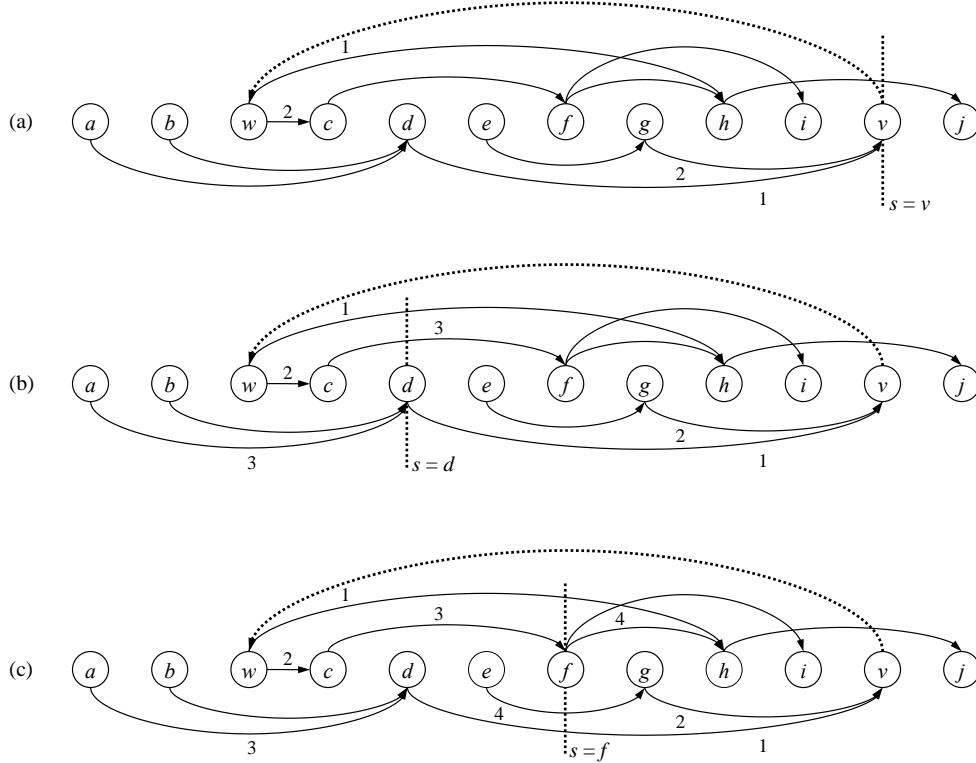

Fig. 9. Soft-threshold search of the graph in Figure 2. Arc traversal order is the same as in Figure 5. Initially $s = v$, $F_A = \{w\}$, $B_A = \{v\}$. (a) Choosing $u = w$, $z = v$ twice causes traversal of compatible pair (w, h) , (d, v) followed by traversal of (w, c) , (g, v) . Now $F_A = \{h, c\}$, $B_A = \{d, g\}$. Choice of $u = h$, $z = d$ moves d to B_P . Choice of $u = h$, $z = g$ moves g to B_P , making B_A empty. (b) New s is d . Now $F_A = \{h, c\}$, $F_P = \{h\}$, $B_A = \{d, g\}$, $B_P = \{d, g\}$. Choice of $u = h$, $z = d$ moves h to F_P . Choice of $u = c$, $z = d$ causes traversal of (c, f) , (a, d) , adding f to F_A and deleting c from F_A . (Vertex a has no incoming arc, so it is not added to B_A .) Choice of $u = f$, $z = d$ moves f to F_P , making F_A empty. (c) New s is f . Now $F_A = \{f\}$, $F_P = \{h, f\}$, $B_A = \{g\}$, $B_P = \{d, g\}$. Choice of $u = f$, $z = g$ causes traversal of (f, h) , (e, g) , deleting g from B_A and making B_A empty. Since B_P is also empty, the search ends. Reordering is the same as in Figure 5.

The remaining freedom in the algorithm is the choice of s . The following observation guides this choice. Suppose s changes because F_A is empty. The algorithm chooses a new s from F_P and makes active all vertices in F_P that are no greater than s . Consider the next change in s . If this change occurs because F_A is again empty, then all the vertices that were made active by the first change of s , including s , are dead, and hence can never become active again. If, on the other hand, this change occurs because B_A is empty, then all the forward vertices that remained passive after the first change in s become dead, and s becomes dead if it is not dead already. That is, either the vertices in F_P no greater than the new s , or the vertices in F_P no less than the new s , are dead after the next change in s . Symmetrically, if s changes because B_A is empty, then either all the vertices in B_P no less than the new s , or all the vertices in B_P no greater than the new s , are dead after the next change in s . To minimize the worst case, we always select s to be the median of the set of choices. This takes time linear in the number of choices [Blum et al. 1973; Schönhage et al. 1976; Dor and Zwick 1999].

THEOREM 4.5. *If each new s is selected to be the median of the set of choices, soft-threshold search takes $O(m^{3/2})$ time over m arc additions.*

PROOF. Consider a soft-threshold search. For each increase in s we charge an amount equal to the number of vertices in F_P when the change occurs; for each decrease in s we charge an amount equal to the number of vertices in B_P when the change occurs. The charge covers the time spent in the code block associated with the change, including the time to find the new s (the median) and the time to make vertices passive or dead, all of which is linear in the charge. The charge also covers any time spent later to make passive any vertices that became active as a result of the change; this time is $O(1)$ for each such vertex. The remainder of the search time is $O(1)$ for initialization plus $O(1)$ per arc traversal. We claim that the total charge is $O(1)$ per arc traversal. The theorem follows from the claim and Theorem 3.3.

The number of vertices in $F \cup B$ is at most the number of arc traversals. We divide the total charge among these vertices, at most two units per vertex. The claim follows.

Consider a change in s other than the last. Suppose this is an increase. Let k be the number of vertices in F_P when this change occurs; k is also the charge for the change. Since s is selected to be the median of F_P , at least $\lceil k/2 \rceil$ vertices in F_P are no greater than s , and at least $\lfloor k/2 \rfloor$ vertices in F_P are no less than s . If the next change in s is an increase, all the vertices in F_P no greater than s must be dead by the time of the next change. If the next change in s is a decrease, all the vertices in F_P no less than s will be made dead by the next change, including s if it is not dead already. In either case we associate the charge of k with the at least $\lceil k/2 \rceil$ vertices that become dead after the change in s but before or during the next change in s .

A symmetric argument applies if s decreases. The charge for the last change in s we associate with the remaining live vertices, at most one unit per vertex. \square

Theorem 4.5 holds (with a bigger constant factor) if each new s is an approximate median of the set of choices; that is, if s is larger than ϵk and smaller than ϵk of the k choices, for some fixed $\epsilon > 0$. An alternative randomized method is to select each new s uniformly at random from among the choices.

THEOREM 4.6. *If each new s is chosen uniformly at random from among the set of choices, soft-threshold search takes $O(m^{3/2})$ expected time over m arc additions.*

PROOF. Each selection of s takes time linear in the number of choices. We charge for the changes in s exactly as in the proof of Theorem 4.5. The search time is then $O(1)$ plus $O(1)$ per arc traversal plus $O(1)$ per unit of charge. We shall show that the expected total charge for a search is at most linear in the number of vertices in $F \cup B$, which in turn is at most the number of arc traversals. The theorem follows from the bound on expected total charge and Theorem 3.3.

The analysis of the expected total charge is much like the analysis [Knuth 1972] of Hoare's "quick select" algorithm [Hoare 1961]. We construct an appropriate recurrence and prove a linear bound by induction. Consider the situation just before some search step. Let $E(k)$ be the maximum expected total future charge, given that at most k distinct vertices are candidates for s during future changes of s . (A vertex can be a candidate more than once, but we only count it once.) The maximum is over the possible current states of all the data structures; the expectation is over future choices of s . We prove by induction on k that $E(k) \leq 4k$.

If s does not change in the future, or if the next change in s is the last one, then the total future charge is at most k . Suppose the next change of s is not the last, and the next choice of s is from among j candidates. Each of these j candidates is selected with probability $1/j$. If the new s is the i^{th} smallest among the candidates, then at least $\min\{i, j-i+1\}$ of these candidates cannot be future candidates. The charge for this change in s is j . The maximum expected future charge, including that for this change in s , is at most $j + \sum_{i=1}^{j/2} (2E(k-i)/j)$ if j is even, at most $j + E(k - \lceil j/2 \rceil)/j + \sum_{i=1}^{\lfloor j/2 \rfloor} (2E(k-i)/j)$ if j is odd. Using the induction hypothesis $E(k') \leq 4k'$ for $k' < k$, we find that the maximum expected future charge is at most $j + \sum_{i=1}^{j/2} (8(k-i)/j) = 4k + j - \sum_{i=1}^{j/2} (8i/j) =$

$4k+j-(4/j)(j/2)(j/2+1) = 4k-2$ if j is even, at most $j+4(k-\lceil j/2 \rceil)/j + \sum_{i=1}^{\lfloor j/2 \rfloor} (8(k-i)/j) = 4k+j-4\lceil j/2 \rceil/j - \sum_{i=1}^{\lfloor j/2 \rfloor} (8i/j) = 4k+j-(4/j)(j/2+1/2 + (j/2-1/2)(j/2+1/2)) < 4k+j-(4/j)(j/2)^2 = 4k$ if j is odd. By induction $E(k) \leq 4k$ for all k .

Over the entire search, there are at most $|F \cup B|$ candidates for s . It follows that the expected total charge over the entire search is at most $4|F \cup B|$, which is at most four times the number of arcs traversed during the search. \square

Soft-threshold search with either method of choosing s uses $O(n+m)$ space, as do all the algorithms we have discussed so far. Katriel and Bodlaender [Katriel and Bodlaender 2006] give a set of examples on which soft-threshold search takes $\Omega(m^{3/2})$ time no matter how s is chosen, so the bounds in Theorems 4.5 and 4.6 are tight.

It is natural to ask whether there is a faster algorithm. To address this question, we consider algorithms that maintain (at least) an explicit list of the vertices in topological order and that do any needed reordering by moving one vertex at a time to a new position in this list. All known algorithms do this or can be modified to do so with at most a constant-factor increase in running time. We further restrict our attention to *local* algorithms, those that update the order after an arc (v, w) with $v > w$ is added by reordering only affected vertices (defined in Section 2: those vertices between w and v , inclusive). These vertices form an interval in the old order and must form an interval in the new order; within the interval, any permutation is allowed as long as it restores topological order. Our algorithms, as well as all previous ones except for those of Shmueli [Shmueli 1983] and Bender et al. [Bender et al. 2009], are local. The following theorem gives a lower bound of $\Omega(n\sqrt{m})$ on the worst-case number of vertices that must be moved by any local algorithm. Thus for sparse graphs ($m/n = O(1)$), soft-threshold search is as fast as possible among local algorithms.

THEOREM 4.7. *Any local algorithm must reorder $\Omega(n\sqrt{m})$ vertices, and hence must take $\Omega(n\sqrt{m})$ time.*

PROOF. Let p and k be arbitrary positive integers such that $p \leq k$. We shall give an example with $n = p(k+1)$ vertices and $m = n-k-1+k(k+1)/2$ arcs that requires at least $pk(k+1)/2 = nk/2$ vertex movements. Since $p \leq k$, $k(k+1)/2 \leq m \leq 3k(k+1)/2$, so $\sqrt{m} = \Theta(k)$. The example is such that, after $n-k-1$ initial arc additions, each subsequent arc addition forces at least p vertices to be moved in the topological order, assuming the algorithm is local. The total number of vertex movements is thus at least $pk(k+1)/2 = \Omega(n\sqrt{m})$. Given any target number of vertices n' and target number of arcs m' , we can choose p and k so that $n = \Theta(n')$ and $m = \Theta(m')$, which gives the theorem.

The construction is quite simple. Let the n vertices be numbered 1 through n in their original topological order. Add $n-k-1$ arcs so that each interval of p consecutive vertices ending in an integer multiple of p forms a path of the vertices in increasing order (so that vertices 1 through p form a path from 1 to p , $p+1$ through $2p$ form a path from $p+1$ to $2p$, and so on). Now there are $k+1$ paths, each containing p vertices. Call these paths P_1, P_2, \dots, P_{k+1} , in increasing order by first (and last) vertex. Add an arc from the last vertex of P_2 (vertex $2p$) to the first vertex of P_1 (vertex 1). This forms a path from $p+1$ through $p+2, p+3, \dots$ to $2p$, then through $1, 2, \dots$ to p . The affected vertices are the vertices 1 through $2p$, and the only way to rearrange them to restore topological order is to move $p+1$ through $2p$ before 1 through p , which takes at least p individual vertex moves. The effect is to swap P_1 and P_2 in the topological order. Now add an arc from the last vertex of P_3 to the first vertex of P_1 . This forces P_1 to swap places with P_3 , again requiring at least p vertex moves. Continue adding one arc at a time in this way, forcing P_1 to swap places with P_4, P_5, \dots, P_{k+1} . After k arcs additions of arcs from the last vertex of P_2, P_3, \dots, P_{k+1} to the first vertex of P_1 , path P_1 has been forced all the way to the top end of the topological order. Now ignore P_1 and repeat the construction with P_2 , forcing it to move past P_3, P_4, \dots, P_{k+1} by adding arcs $(3p, p+1), (4p, p+1), \dots, ((k+1)p, p+1)$. Do the same with P_3, P_4, \dots, P_k . The total number

of arcs added that force vertex moves is $k(k+1)/2$. Each of these added arcs forces at least k vertex moves. Figure 10 gives an example of the construction. \square

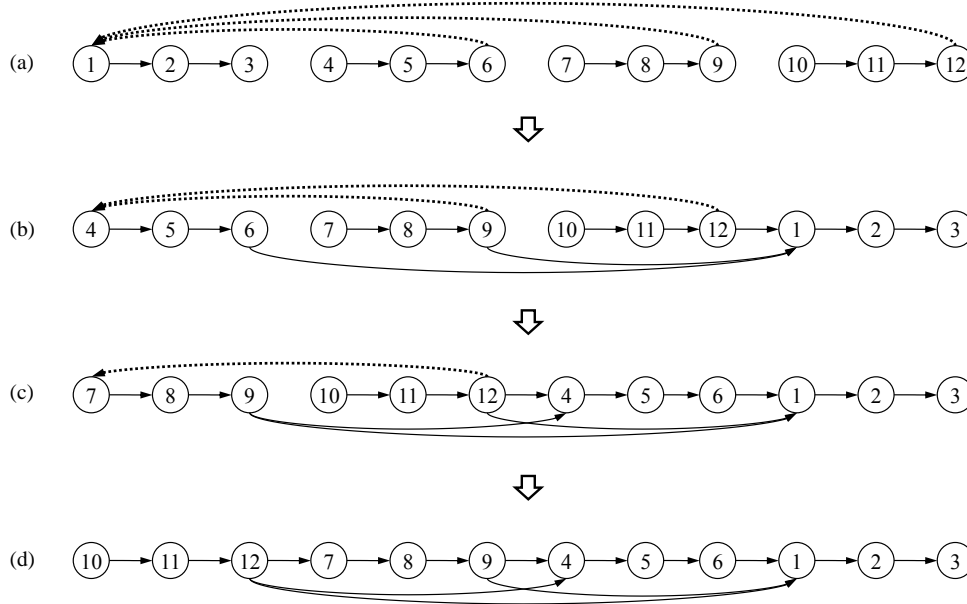

Fig. 10. The $\Omega(nm^{1/2})$ vertex reordering construction for $p = 3$ and $k = 3$, yielding an example with $n = 12$ vertices and $m = 14$ arcs. (a) Insertion of arc $(6, 1)$ moves 1, 2, 3 past 4, 5, 6. Insertion of $(9, 1)$ moves 1, 2, 3 past 7, 8, 9. Insertion of $(12, 1)$ moves 1, 2, 3 past 10, 11, 12. (b) Insertion of $(9, 4)$ moves 4, 5, 6 past 7, 8, 9. Insertion of $(12, 4)$ moves 4, 5, 6 past 10, 11, 12. (c) Insertion of $(12, 7)$ moves 7, 8, 9 past 10, 11, 12. (d) Final order.

The $\Omega(n\sqrt{m})$ bound on vertex reorderings is tight. An algorithm that achieves this bound is a two-way search that does not alternate forward and backward arc traversals but instead does forward arc traversals until visiting an unvisited vertex less than v , then does backward arc traversals until visiting an unvisited vertex greater than w , and repeats. Each forward traversal is along an arc (u, x) with u minimum; each backward traversal is along an arc (y, z) with z maximum. Searching continues until a cycle is detected or there is no compatible pair of untraversed arcs. If the search stops without detecting a cycle, the algorithm reorders the vertices in the same way as in two-way compatible search. One can prove that this method reorders $O(n\sqrt{m})$ vertices over m arc additions by counting related vertex pairs (as defined in the next section: two vertices are related if one path contains both). Unfortunately we do not know an implementation of this algorithm with an overall time bound approaching the bound on vertex reorderings.

For algorithms that reorder one vertex at a time but are allowed to move unaffected vertices, the only lower bound known is the much weaker one of Ramalingam and Reps [Ramalingam and Reps 1994]. They showed that $n - 1$ arc additions can force any algorithm, local or not, to do $\Omega(n \log n)$ vertex moves.

5. TOPOLOGICAL SEARCH

Soft-threshold search is efficient on sparse graphs but becomes less and less efficient as the graph becomes denser; indeed, if $m = \Omega(n^2)$ the time bound is $O(n^3)$, the same as that of one-way limited search (Section 2). In this section we give an alternative algorithm that is efficient for dense

```

procedure TOPOLOGICAL-SEARCH(vertex  $v$ , vertex  $w$ )
   $F = []$ ;  $B = []$ ;  $inject(w, F)$ ;  $inject(v, B)$ 
   $i = position(w)$ ;  $j = position(v)$ ;  $vertex(i) = vertex(j) = null$ 
  while true do
     $i = i + 1$ 
    while  $i < j$  and  $\forall u \in F (A(position(u), i) = 0)$  do  $i = i + 1$ 
    if  $i = j$  then return else
       $inject(vertex(i), F)$ ;  $vertex(i) = null$ 
    end
     $j = j - 1$ 
    while  $i < j$  and  $\forall z \in B (A(j, position(z)) = 0)$  do  $j = j - 1$ 
    if  $i = j$  then return else
       $inject(vertex(j), B)$ ;  $vertex(j) = null$ 
    end
  end

```

Fig. 11. Implementation of topological search.

graphs. The algorithm uses two-way search, but differs in three ways from the methods discussed in Sections 3 and 4: it balances vertices visited instead of arcs traversed (as in the method sketched at the end of Section 4); it searches the topological order instead of the graph; and it uses a different reordering method, which has the side benefit of making it a topological sorting algorithm. We call the algorithm *topological search*.

We represent the topological order by an explicit mapping between the vertices and the integers from 1 to n . We denote by $position(v)$ the number of vertex v and by $vertex(i)$ the vertex with number i . We implement $vertex$ as an array. The initial numbering is arbitrary; it is topological since there are no arcs initially. If v and w are vertices, we test $v < w$ by comparing $position(v)$ to $position(w)$. We represent the graph by an adjacency matrix $A : A(v, w) = 1$ if (v, w) is an arc, $A(v, w) = 0$ if not. Testing whether (v, w) is an arc takes $O(1)$ time, as does adding an arc. Direct representation of A uses $O(n^2)$ bits of space; representation of A by a hash table reduces the space to $O(n + m)$ but makes the algorithm randomized.

To simplify the running time analysis and the extension to strong component maintenance (Section 6), we test for cycles after the search. Thus the algorithm consists of three parts: the search, the cycle test, and the vertex reordering. Let (v, w) be a new arc with $v > w$. The search examines every affected vertex (those between w and v in the order, inclusive). It builds a queue F of vertices reachable from w by searching forward from w , using a current position i , initially $position(w)$. Concurrently, it builds a queue B of vertices from which v is reachable by searching backward from v , using a current position j , initially $position(v)$. It alternates between adding a vertex to F and adding a vertex to B until the forward and backward searches meet. When adding a vertex z to F or B , the method sets $vertex(position(z)) = null$.

In giving the details of this method, we use the following notation for queue operations: $[]$ denotes an empty queue; $inject(x, Q)$ adds element x to the back of queue Q ; $pop(Q)$ deletes the front element x from queue Q and returns x ; if Q is empty, $pop(Q)$ leaves Q empty and returns null. Do the search by calling $TOPOLOGICAL-SEARCH(v, w)$, where procedure $TOPOLOGICAL-SEARCH$ is defined in Figure 11.

Once the search finishes, test for a cycle by checking whether there is an arc (u, z) with u in F and z in B . If there is no such arc, reorder the vertices as follows. Let F and B be the queues at the end of the search, and let k be the common value of i and j at the end of the search. Then $vertex(k) = null$. If the search stopped after incrementing i , then $vertex(k)$ was added to B , and F and B contain the same number of vertices. Otherwise, the search stopped after decrementing j , $vertex(k)$ was added to F , and F contains one more vertex than B . In either case, the number of positions $g \geq k$ such that $vertex(g) = null$ is $|F|$, and the number of positions $g < k$ such that $vertex(g) = null$ is $|B|$. Reinsert the vertices in $F \cup B$ into the vertex array, moving additional

```

procedure REORDER
  while  $F \neq []$  do
    if  $vertex(i) \neq null$  and  $\exists u \in F(A(u, vertex(i)) = 1)$  then
       $inject(vertex(i), F); vertex(i) = null$ 
    end
    if  $vertex(i) = null$  then
       $x = pop(F); vertex(i) = x; position(x) = i$ 
    end
     $i = i + 1$ 
  end
  while  $B \neq []$  do
     $j = j - 1$ 
    if  $vertex(j) \neq null$  and  $\exists z \in B(A(vertex(j), z) = 1)$  then
       $inject(vertex(j), B); vertex(j) = null$ 
    end
    if  $vertex(j) = null$  then
       $y = pop(B); vertex(j) = y; position(y) = j$ 
    end
  end

```

Fig. 12. Implementation of reordering.

vertices as necessary, by calling REORDER, using as the initial values of F , B , i , j their values at the end of the search, where procedure REORDER is defined in Figure 12.

The reordering process consists of two almost-symmetric while loops. The first loop reinserts the vertices in F into positions k and higher. Variable i is the current position. If $vertex(i)$ is a vertex q with an arc from a vertex currently in F , vertex q is added to the back of F and $vertex(i)$ becomes null: vertex q must be moved to a higher position. If $vertex(i)$ becomes null, or if $vertex(i)$ was already null, the front vertex in F is deleted from F and becomes $vertex(i)$. The second loop reinserts the vertices in B into positions $k - 1$ and lower in symmetric fashion. The only difference between the loops is that the forward loop increments i last, whereas the backward loop decrements j first, to avoid examining $vertex(k)$. The forward and backward loops are completely independent and can be executed in parallel. (This is not true of the forward and backward searches.) Figure 13 gives an example of topological search and reordering.

THEOREM 5.1. *Topological search is correct.*

PROOF. Let (v, w) be a new arc such that $v > w$. The search maintains the invariant that every vertex in F is reachable from w and v is reachable from every vertex in B . Thus if there is an arc (u, z) with u in F and z in B , there is a cycle. Suppose the addition of (v, w) creates a cycle. The cycle consists of (v, w) and a path P from w to v of vertices in increasing order. Let u be the largest vertex on P that is in F at the end of the search. Since $u \neq v$, there is an arc (u, z) on P . Vertex z must be in B , or the search would not have stopped. We conclude that the algorithm reports a cycle if and only if the addition of (v, w) creates one.

Suppose the addition of (v, w) does not create a cycle. When the search stops, the number of positions $g \geq i$ such that $vertex(g) = null$ is $|F|$. The forward reordering loop maintains this invariant as it updates F . It also maintains the invariant that once position i is processed, every position from k to i , inclusive, is non-null. Thus if $i = n + 1$, F must be empty, and the loop terminates. Symmetrically, the backward reordering loop terminates before j can become 0. Thus all vertices in $F \cup B$ at the end of the search are successfully reordered; some other vertices may also be reordered. Let \bar{F} and \bar{B} be the sets of vertices added to F and to B , respectively, during the search and reordering. Vertices in \bar{F} move to higher positions, vertices in \bar{B} move to lower positions, and no other vertices move.

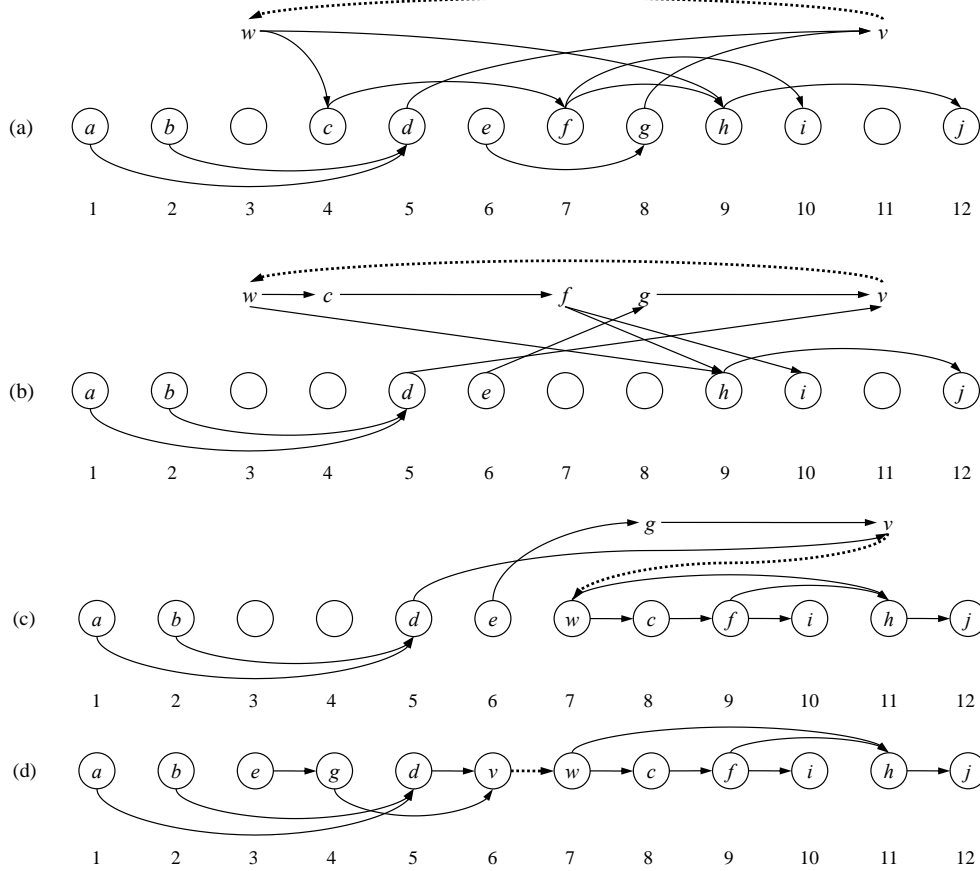

Fig. 13. Topological search and reordering of the graph in Figure 2. (a) Initially positions 3 and 11, of w and v , respectively, become empty, $F = [w]$, $B = [v]$. The search adds c to F , g to B , f to F , and stops with $i = j = 7$. (b) Forward reordering begins from position 7. Vertex w drops into position 7, c drops into position 8. Vertex h in position 9 has an arc from f , still in F : h is added to F , f drops into position 9. Vertex i in position 10 has no arc from any vertex still in F . Vertex h drops into position 11. (c) Backward reordering begins from position 6. Vertex e has an arc to g ; e is added to B and replaced by v . Vertices g and e drop into positions 4 and 3, respectively. (d) Final order. Forward and backward reordering are independent and can be done in either order or concurrently.

All vertices in \overline{F} are reachable from w , and v is reachable from all vertices in \overline{B} . We show by case analysis that after the reordering every arc (x, y) has $x < y$. There are five cases, of which two pairs are symmetric. Suppose x and y are both in $\overline{F} \cup \overline{B}$. Since there is no cycle, it cannot be the case that x is in \overline{F} and y is in \overline{B} . The reordering moves all vertices in \overline{F} after all vertices in \overline{B} without changing the order of vertices in \overline{F} and without changing the order of vertices in \overline{B} . It follows that $x < y$ after the reordering. This includes the case $(x, y) = (v, w)$, since w is in \overline{F} and v is in \overline{B} . Suppose y is in \overline{F} and x is not in $\overline{F} \cup \overline{B}$. The reordering does not move x and moves y higher in the order, so $x < y$ after the reordering. The case of x in \overline{B} and y not in $\overline{F} \cup \overline{B}$ is symmetric. Suppose x is in \overline{F} and y is not in $\overline{F} \cup \overline{B}$. Since $x < y$ before the reordering, the first loop of the reordering must reinsert x before it reaches the position of y ; otherwise y would be in \overline{F} . Thus $x < y$ after the reordering. The case y in \overline{B} and x not in $\overline{F} \cup \overline{B}$ is symmetric. \square

To bound the running time of topological search, we extend the concept of relatedness to vertex pairs. We say two vertices are *related* if they are on a common path. Relatedness is symmetric; order on the path does not matter.

LEMMA 5.2. *Over m arc additions, topological search spends $O(n^2)$ time testing for cycles.*

PROOF. Suppose addition of an arc (v, w) triggers a search. Let F and B be the values of the corresponding variables at the end of the search. The test for cycles takes $O(|F||B|)$ time. If this is the last arc addition, the test takes $O(n^2)$ time. Each earlier addition does not create a cycle; for such an addition, each pair x in F and y in B is related after the addition but not before: before the reordering $x < y$, so if x and y were related there would be a path from x to y , and the addition of (v, w) would create a cycle, consisting of a path from w to x , the path from x to y , a path from y to v , and arc (v, w) . Since there are at most $\binom{n}{2}$ related vertex pairs, the time for all cycle tests other than the last is $O(n^2)$. \square

For each move of a vertex during reordering, we define the *distance* of the move to be the absolute value of the difference between the positions of the vertex in the old and new orders.

LEMMA 5.3. *Over all arc additions, except the last one if it creates a cycle, the time spent by topological search doing search and reordering is at most a constant times the sum of the distances of all the vertex moves.*

PROOF. Consider an arc addition that triggers a search and reordering. Consider a vertex q that is moved to a higher position; that is, it is added to F during either the search or the reordering and eventually placed in a new position during the reordering. Let i_1 be its position before the reordering and i_2 its position after the reordering. When q is added to F , $i = i_1$; when q is removed from F , $i = i_2$. For each value of i greater than i_1 and no greater than i_2 , there may be a test for the existence of an arc $(q, \text{vertex}(i))$: such a test can occur during forward search or forward reordering but not both. The number of such tests is thus at most $i_2 - i_1$, which is the distance q moves. A symmetric argument applies to a vertex moved to a lower position. Every test for an arc is covered by one of these two cases. Thus the number of arc tests is at most the sum of the distances of vertex moves. The total time spent in search and reordering is $O(1)$ per increment of i , per decrement of j , and per arc test. For each increment of i or decrement of j there is either an arc test or an insertion of a vertex into its final position. The number of such insertions is at most one per vertex moved. The lemma follows. \square

It remains to analyze the sum of the distances of the vertex moves. To simplify the analysis, we decompose the moves into pairwise swaps of vertices. Consider sorting a permutation of 1 through n by doing a sequence of pairwise swaps of out-of-order elements. The *distance* of a swap is twice the absolute value of the difference between the positions of the swapped elements; the factor of two accounts for the two elements that move. The sequence of swaps is *proper* if, once a pair is swapped, no later swap reverses its order.

Consider the behavior of topological search over a sequence of arc additions, excluding the last one if it creates a cycle. Identify the vertices with their final positions. Then the topological order is a permutation, and the final permutation is sorted.

LEMMA 5.4. *There is a proper sequence of vertex swaps whose total distance equals the sum of the distances of all the reordering moves.*

PROOF. Consider an arc addition that triggers a search and reordering. As in the proof of Theorem 5.1, let \bar{F} and \bar{B} be the sets of vertices added to F and to B , respectively, during the search and reordering. Consider the positions of the vertices in $\bar{F} \cup \bar{B}$ before and after the reordering. After the reordering, these positions from lowest to highest are occupied by the vertices in \bar{B} in their original order, followed by the vertices in \bar{F} in their original order. We describe a sequence of swaps that moves the vertices in $\bar{F} \cup \bar{B}$ from their positions before the reordering to their positions after the

reordering. Given the outcome of the swaps so far, the next swap is of any two vertices x in \overline{F} and y in \overline{B} such that x is in a smaller position than y and no vertex in $\overline{F} \cup \overline{B}$ is in a position between that of x and that of y . The swap of x and y moves x higher, moves y lower, and preserves the order of the vertices in \overline{F} as well as the order of the vertices in \overline{B} . If no swap is possible, all vertices in \overline{F} must follow all vertices in \overline{B} , and since swaps preserve the order within \overline{F} and within \overline{B} the vertices are now in their positions after the reordering. Only a finite number of swaps can occur, since each vertex can only move a finite distance (higher for a vertex in \overline{F} , lower for a vertex in \overline{B}). The total distance of the moves of the vertices in \overline{F} is exactly half the distance of the swaps, as is the total distance of the moves of the vertices in \overline{B} . Any particular pair of vertices is swapped at most once. Repeat this construction for each arc addition. If an arc addition causes a swap of x and y , with x moving higher and y moving lower, then the arc addition creates a path from y to x , and no later arc addition can cause a swap of x and y . Thus the swap sequence is proper. \square

The following lemma was proved by Ajwani et al. [Ajwani et al. 2006] as part of the analysis of their $O(n^{11/4})$ -time algorithm. Their proof uses a linear program. We give a combinatorial argument.

LEMMA 5.5. [Ajwani et al. 2006] *Given an initial permutation of 1 through n , any proper sequence of swaps has total distance $O(n^{5/2})$.*

PROOF. If Π is a permutation of 1 to n , we denote by $\Pi(i)$ the i^{th} element of Π . We define the *potential* of Π to be $\sum_{i < j} (\Pi(i) - \Pi(j))$. The potential is always between $-n^3$ and n^3 . We compute the change in potential caused by a swap in a proper swap sequence. Let Π be the permutation before the swap, and let $i < j$ be the positions in Π of the pair of elements $(\Pi(i)$ and $\Pi(j))$ that are swapped. The distance d of the swap is $2(j - i)$. Since the swap sequence is proper, $\Pi(i) > \Pi(j)$. Swapping $\Pi(i)$ and $\Pi(j)$ reduces the contribution to the potential of the pair i, j by $2(\Pi(i) - \Pi(j))$. The swap also changes the contributions to the potential of pairs other than i, j , specifically those pairs exactly one of whose elements is i or j . We consider three cases for the other element of the pair, say k . If $k < i$, the swap increases the contribution of k, i by $\Pi(i) - \Pi(j)$ and decreases the contribution of k, j by $\Pi(i) - \Pi(j)$, for a net change of zero. Similarly, if $j < k$, the swap decreases the contribution of i, k by $\Pi(i) - \Pi(j)$ and increases the contribution of j, k by $\Pi(i) - \Pi(j)$, for a net change of zero. More interesting is what happens if $i < k < j$. In this case the swap decreases the contribution of both i, k and k, j by $\Pi(i) - \Pi(j)$. There are $j - i - 1$ such values of k . Summing over all pairs, we find that the swap decreases the potential of the permutation by $2(\Pi(i) - \Pi(j))(1 + j - i - 1) = d(\Pi(i) - \Pi(j))$.

Call a swap of $\Pi(i)$ and $\Pi(j)$ *small* if $\Pi(i) - \Pi(j) < \sqrt{n}$ and *big* otherwise. Because the swap sequence is proper, a given pair can be swapped at most once. Thus there are $O(n^{3/2})$ small swaps. Each has distance at most $2(n - 1)$, so the sum of the distances of all small swaps is $O(n^{5/2})$. A big swap of distance d reduces the potential by at least $d\sqrt{n}$. Since the sum of the potential decreases over all swaps is $O(n^3)$, the sum of the distances of all big swaps is $O(n^{5/2})$. \square

The proof of Lemma 5.5 does not require that the swap sequence be proper; it suffices that every swap is of an out-of-order pair and no pair of elements is swapped more than once. The lemma may even be true if all swaps are of out-of-order pairs with some pairs swapped repeatedly, but our proof fails in this case, because our bound on the distance of the small swaps requires that there be $O(n^{3/2})$ of them.

THEOREM 5.6. *Over m arc additions, topological search spends $O(n^{5/2})$ time.*

PROOF. Topological search spends $O(n^2)$ time on the last arc addition. By Lemmas 5.2-5.5, it spends $O(n^{5/2})$ on all the rest. \square

The bound of Theorem 5.6 may be far from tight. In the remainder of this section we discuss lower bounds on the running time of topological search, and we speculate on improving the upper bound.

Katriel [Katriel 2004] showed that any topological sorting algorithm that is local (as defined in Section 2: the algorithm reorders only affected vertices) must do $\Omega(n^2)$ vertex renumberings on a sequence of arc additions that form a path. This bound is $\Omega(n)$ amortized per arc on a graph of $O(n)$ arcs. She also proved that the topological sorting algorithm of Pearce and Kelly [Pearce and Kelly 2006] does $O(n^2)$ vertex renumberings. Since topological search is a local topological sorting algorithm, her lower bound applies to this algorithm. Her lower bound on vertex reorderings is tight for topological search, since a proper sequence of swaps contains at most $\binom{n}{2}$ swaps, and each pair of reorderings corresponds to at least one swap.

To get a bigger lower bound, we must bound the total distance of vertex moves, not their number. Ajwani [Ajwani 2008] gave a result for a related problem that implies the following: on a sequence of arc additions that form a path, topological search can take $\Omega(n^2 \log n)$ time. We proved this result independently in our conference paper [Haeupler et al. 2008]; our proof uses the same construction as Ajwani's proof. This bound is $\Omega(n \log n)$ amortized per arc on a graph of $O(n)$ arcs.

We do not know if Ajwani's bound is tight for graphs with $O(n)$ arcs, but it is not tight for denser graphs. There is an interesting connection between the running time of topological search and the notorious k -levels problem of computational geometry. Uri Zwick (private communication, 2009) pointed this out to us. The k -levels problem is the following: Consider the intersections of n lines in the plane in general position: each intersection is of only two lines, and the intersections have distinct x -coordinates. An intersection is a k -intersection if there are exactly k lines below it (and $n - k - 2$ lines above it). What is the maximum number of k -intersections as a function of n and k ? For our purposes it suffices to consider n even and $k = n/2 - 1$. We call an intersection with $n/2 - 1$ lines below it a *halving intersection*. The current best upper and lower bounds on the maximum number of halving intersections are $O(n^{4/3})$ [Dey 1998] and $\Omega(n2^{\sqrt{2} \lg n} / \sqrt{\lg n})$ [Nivasch 2008]; see also [Tóth 2001]).

The relationship between the k -levels problem and our problem does not require that the lines be straight; it only requires that each pair intersect only once. Thus instead of a set of lines we consider a set of *pseudolines*, arbitrary continuous functions from the real numbers to the real numbers, each pair of which intersect at most once. Such a set is in *general position* if no point is common to three or more pseudolines, no two intersections of pseudolines have the same x -coordinate, and each intersection is a crossing intersection: if pseudolines P and Q intersect and P is above Q to the left of the intersection, then Q is above P to the right of the intersection. The best bounds on the number of halving intersections of $2n$ pseudolines in general position are $O(n^{4/3})$ ([Tamaki and Tokuyama 2003]; see also [Sharir and Smorodinsky 2003]) (the same as for lines) and $\Omega(n2^{\sqrt{2} \lg n})$ [Zwick 1986]. The latter gives a lower bound of $\Omega(n^2 2^{\sqrt{2} \lg n})$ on the worst-case running time of topological search, as we now show.

THEOREM 5.7. *Let n be even. On a graph of $3n/2$ vertices, topological search can spend $\Omega(n)$ time per arc addition for at least $H(n)$ arc additions, where $H(n)$ is the maximum number of halving intersections of n pseudolines in the plane in general position.*

PROOF. Given a set of n pseudolines with $H(n)$ halving intersections, we construct a sequence of $H(n)$ arc additions on a graph of $3n/2$ vertices on which topological search spends $\Omega(n)$ time on each arc addition. Given such a set of pseudolines, choose a value x_0 of the x -coordinate sufficiently small that all the halving intersections have x -coordinates larger than x_0 . Number the pseudolines from 1 to n from highest to lowest y -coordinate at x_0 , so that the pseudoline with the highest y -coordinate gets number 1 and the one with the lowest gets number n . Construct a graph with $3n/2$ vertices and an initial (arbitrary) topological order. Number the first $n/2$ vertices in order from n down to $n/2 + 1$, and number the last $n/2$ vertices in order from $n/2$ down to 1, so that the first vertex gets number n , the $(n/2)^{\text{th}}$ gets number $n/2 + 1$, the middle $n/2$ get no number, the $(n + 1)^{\text{st}}$

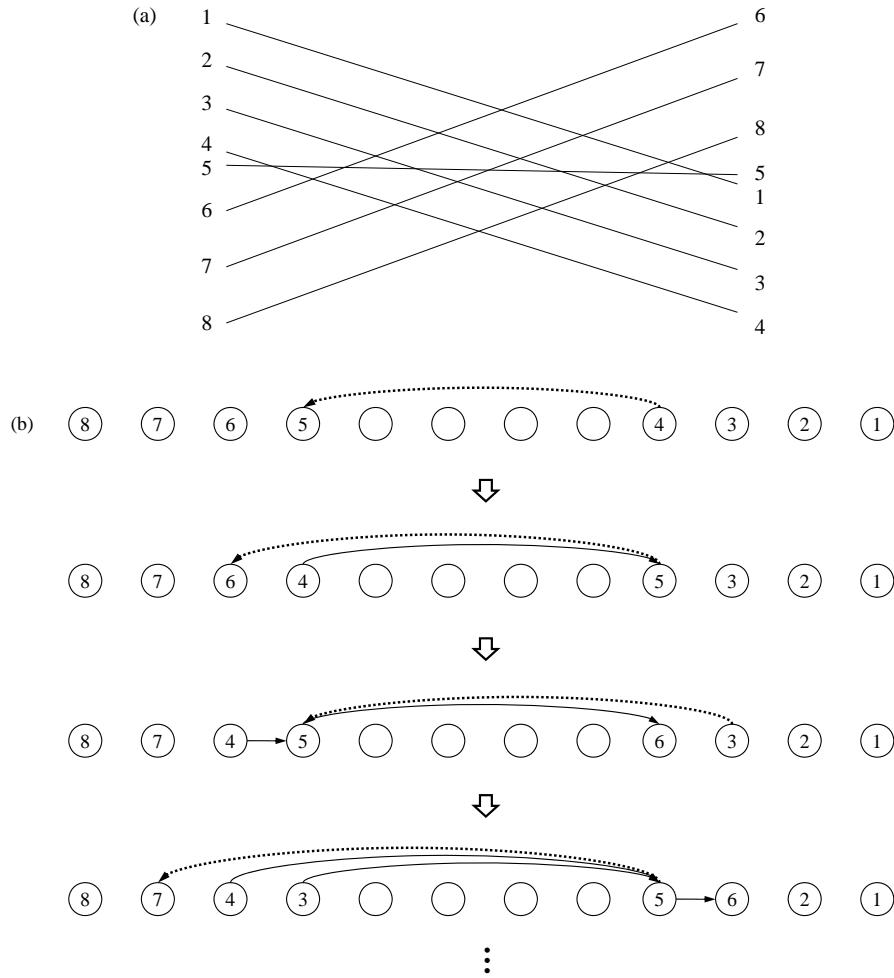

Fig. 14. (a) A set of $n = 8$ pseudolines with $H(n) = 7$ halving intersections. Although the pseudolines are straight in this example, in general they need not be. (b) The corresponding sequence of arc additions on a graph of $3n/2 = 12$ vertices on which topological search takes $\Omega(nH(n))$ time. The arc additions correspond to the halving intersections processed in increasing order by x -coordinate; only the first four arc additions are shown.

gets number $n/2$, and the last gets number 1. These numbers are permanent and are a function only of the initial order. Identify vertices by their number. Process the halving intersections in order by x -coordinate. If the k^{th} halving intersection is of pseudolines i and j with $i < j$, add an arc (i, j) to the graph. To the left of the intersection, pseudoline i is above pseudoline j ; to the right of the intersection, pseudoline j is above pseudoline i . Figure 14 illustrates this construction.

Since each arc (i, j) has $i < j$, the graph remains acyclic. Since two pseudolines have only one intersection, a given arc is added only once. Consider running topological search on this set of arc additions. We claim that each arc addition moves exactly one vertex from the last third of the topological order to the first third and vice-versa; the vertices in the middle third are never reordered. Each such arc addition takes $\Omega(n)$ time, giving the theorem.

To verify the claim, we prove the following invariant on the number of arc additions: the set of vertices in the first or last third, respectively, of the topological order have the same numbers as

the bottom or top half of the pseudolines, respectively. In particular, a halving intersection of two pseudolines i, j with $i < j$ corresponds to a swap of vertices i in the top third and j in the bottom third, giving the claim.

Intersections that are not halving intersections preserve the invariant. Suppose the invariant is true just to the left of a halving intersection of pseudolines i and j with $i < j$. Just to the left of the intersection, pseudolines i and j are the $n/2$ and $n/2 + 1$ highest pseudolines, respectively. By the induction hypothesis, just before the addition of (i, j) vertex i is in the last third of the topological order and vertex j is in the first third. Suppose that just before the addition of (i, j) there is an arc (j, k) with k in the first third. Then $j < k$, but pseudoline k is in the bottom half and hence must be below pseudoline j . This is impossible, since the existence of the arc (j, k) implies that pseudoline k crossed above pseudoline j to the left of the intersection of i and j . Thus there can be no such arc (j, k) . Symmetrically, there can be no arc (k, i) with k in the last third. It follows that the topological search triggered by the addition of (i, j) will compute a set F all of whose vertices except j are in the last third and a set B all of whose vertices except i are in the first third. The subsequent reordering will move i to the first third, move j to the last third, and possibly reorder other vertices within the first and last thirds. Thus the invariant remains true after the addition of (i, j) . By induction the invariant holds, giving the claim, and the theorem. \square

COROLLARY 5.8. *There is a constant $c > 0$ such that, for all n , there is a sequence of arc additions on which topological search takes $cn^2 2^{\sqrt{2} \lg n}$ time.*

Unfortunately the reduction in the proof of Theorem 5.7 goes only one way. We have been unable to construct a reduction in the other direction, nor are we able to derive a better upper bound for topological search via the methods used to derive upper bounds on the number of halving intersections.

6. STRONG COMPONENTS

All the known topological ordering algorithms can be extended to the maintenance of strong components with at most a constant-factor increase in running time. Pearce [Pearce 2005] and Pearce and Kelly [Pearce and Kelly 2003] sketch how to extend their algorithm and that of Marchetti-Spaccamela et al. [Marchetti-Spaccamela et al. 1996] to strong component maintenance. Here we describe how to extend soft-threshold search and topological search. The techniques differ slightly for the two algorithms, since one algorithm is designed for the sparse case and the other for the dense case.

We formulate the problem as follows: Maintain the partition of the vertices defined by the strong components. For each strong component, maintain a *canonical vertex*. The canonical vertex represents the component; the algorithm is free to choose any vertex in the component to be the canonical vertex. Support the query $find(v)$, which returns the canonical vertex of the component containing vertex v . Maintain a list of the canonical vertices in a topological order of the corresponding components.

To represent the vertex partition, we use a disjoint set data structure [Tarjan 1975; Tarjan and van Leeuwen 1984]. This structure begins with the partition consisting of singletons and supports find queries and the operation $unite(x, y)$, which, given canonical vertices x and y , forms the union of the sets containing x and y and makes x the canonical vertex of the new set. If the sets are represented by trees, the finds are done using path compression, and the unites are done using union by rank, the amortized time per find is $O(1)$ if the total time charged for the unites is $O(n \log n)$ [Tarjan and van Leeuwen 1984]. (In fact, the time charged to the unites can be made much smaller, but this weak bound suffices for us.) Since searching and reordering take much more than $\Omega(n \log n)$ time, we can treat the set operations as taking $O(1)$ amortized time each.

To maintain strong components using soft-threshold search, we represent the graph by storing, for each canonical vertex x , a list of arcs out of its component, namely those arcs (y, z) with $find(y) = x$, and a list of arcs into its component, namely those arcs (y, z) with $find(z) = x$. This represents

```

macro SEARCH-STEP(vertex  $u$ , vertex  $z$ )
  ( $q, g$ ) =  $out(u)$ ; ( $h, r$ ) =  $in(z)$ 
   $out(u)$  =  $next-out((q, g))$ ;  $in(z)$  =  $next-in((h, r))$ 
   $x = f(g)$ ; if  $out(u) = first-out(u)$  then  $F_A = F_A - \{u\}$ 
   $y = f(h)$ ; if  $in(z) = first-in(z)$  then  $B_A = B_A - \{z\}$ 
  if  $u = x$  then delete ( $q, g$ ); if  $y = z$  then delete ( $h, r$ )
  if  $x \notin F$  then
     $F = F \cup \{x\}$ ;  $out(x)$  =  $first-out(x)$ 
    if  $out(x) \neq null$  then  $F_A = F_A \cup \{x\}$ 
  end
  if  $y \notin B$  then
     $B = B \cup \{y\}$ ;  $in(y)$  =  $first-in(y)$ 
    if  $in(y) \neq null$  then  $B_A = B_A \cup \{y\}$ 
  end

```

Fig. 15. Redefinition of SEARCH-STEP to find strong components using soft-threshold search.

the graph of strong components, except that there may be multiple arcs between the same pair of strong components, and there may be loops, arcs whose ends are in the same component. When doing a search, we delete loops instead of traversing them. When the addition of an arc (v, w) combines several components into one, we form the incoming list and the outgoing list of the new component by combining the incoming lists and outgoing lists, respectively, of the old components. This takes $O(1)$ time per old component, if the incoming and outgoing lists are circular. Deletion of a loop takes $O(1)$ time if the arc lists are doubly linked.

Henceforth we identify each strong component with its canonical vertex, and we abbreviate $find(x)$ by $f(x)$. If a new arc (v, w) has $f(v) > f(w)$, do a soft-threshold search forward from $f(w)$ and backward from $f(v)$. During the search, do not stop when a forward arc traversal reaches a component in B or when a backward arc traversal reaches a component in F . Instead, allow components to be in both F and B . Once the search stops, form the new component, if any. Then reorder the canonical vertices and delete from the order those that are no longer canonical. Here are the details. When a new arc (v, w) has $f(v) > f(w)$, do the search by calling SOFT-THRESHOLD-SEARCH($f(v), f(w)$), where SOFT-THRESHOLD-SEARCH is defined as in Section 4 but with the macro SEARCH-STEP redefined as in Figure 15. The new version of SEARCH-STEP is just like the old one except that it visits canonical vertices instead of all vertices, it uses circular instead of linear arc lists, and it does not do cycle detection: SOFT-THRESHOLD-SEARCH terminates only when F_A or B_A is empty, and it always returns null.

Once the search finishes, let $t = \min(\{f(v)\} \cup \{x \in F \mid out(x) \neq null\})$. Compute the sets $F_<$ and $B_>$. Find the new component, if any, by running a static linear-time strong components algorithm on the subgraph of the graph of strong components whose vertex set is $X = F_< \cup \{t\} \cup B_>$ and whose arc set is $Y = \{(f(u), f(x)) \mid (u, x) \text{ is an arc with } f(u) \text{ in } F_< \text{ and } f(u) \neq f(x)\} \cup \{(f(y), f(z)) \mid (y, z) \text{ is an arc with } f(z) \in B_> \text{ and } f(y) \neq f(z)\}$. If a new component is found, combine the old components it contains into a new component with canonical vertex v .

Reorder the list of vertices in topological order by moving the vertices in $X - \{t\}$ as in Section 3. Then delete from the list all vertices that are no longer canonical, namely the canonical vertices other than $f(v)$ of the old components contained in the new component.

Remark: Since the addition of (v, w) can only form a single new component, running a strong components algorithm to find this component is overkill. A simpler alternative is to unmark all vertices in X and then run a forward depth-first search from $f(w)$, traversing arcs in Y . During the search, mark vertices as follows: Mark $f(v)$ if it is reached. When retreating along an arc $(f(u), f(x))$, mark $f(u)$ if $f(x)$ is marked. At the end of the search, the marked vertices are the canonical vertices contained in the new component.

THEOREM 6.1. *Maintaining strong components via soft-threshold search is correct.*

PROOF. By induction on the number of arc additions. Consider the graph of strong components just before an arc (v, w) is added. This addition forms a new component if and only if $f(v) > f(w)$ and there is a path from $f(w)$ to $f(v)$. Furthermore the old components contained in the new component are exactly the components on paths from $f(w)$ to $f(v)$. The components on such a path are in increasing order, so the path consists of a sequence of one or more components in $F_{<}$, possibly t , and a sequence of one or more components in $B_{>}$. Each arc on such a path is in Y . It follows that the algorithm correctly forms the new component. If there is no new component, the reordering is exactly the same as in Section 3, so it correctly restores topological order. Suppose there is a new component. Then certain old components are combined into one, and their canonical vertices other than $f(v)$ are deleted from the list of canonical vertices in topological order. We must show that the new order is topological. The argument in the proof of Theorem 3.1 applies, except that there are some new possibilities. Consider an arc (x, y) other than (v, w) . One of the cases in the proof of Theorem 3.1 applies unless at least one of x and y is in the new component. If both are in the new component, then (x, y) becomes a loop. Suppose just one, say y , is in the new component. Then $f(x)$ cannot be forward, or it would be in the new component. Either $f(x)$ is in $B_{>}$ or $f(x)$ is not in X ; in either case, $f(x)$ precedes $f(v)$ after the reordering. The argument is symmetric if x but not y is in the new component. \square

To bound the running time of the strong components algorithm we need to extend Lemma 3.2 and Theorem 3.3.

LEMMA 6.2. *Suppose the addition of (v, w) triggers a search. Let (u, x) and (y, z) , respectively, be arcs traversed forward and backward during the search, not necessarily during the same search step, such that $f(u) < f(z)$. Then either (u, x) and (y, z) are unrelated before the addition of (v, w) but related afterward, or they are related before the addition and the addition makes them into loops.*

PROOF. After (v, w) is added, there is a path containing both of them, so they are related after the addition. If they were related before the addition, then there must be a path containing (u, x) followed by (y, z) . After the addition there is a path from z to u , so u, x, y , and z are in the new component, and both (u, x) and (y, z) become loops. \square

THEOREM 6.3. *Over m arc additions, the strong components algorithm does $O(m^{3/2})$ arc traversals.*

PROOF. Divide the arc traversals during a search into those of arcs that become loops as a result of the arc addition that triggered the search, and those that do not. Over all searches, there are at most $2m$ traversals of arcs that become loops: each such arc can be traversed both forward and backward. By Lemma 6.2 and the proof of Theorem 3.3, there are at most $4m^{3/2}$ traversals of arcs that do not become loops. \square

THEOREM 6.4. *Maintaining strong components via soft-threshold search takes $O(m^{3/2})$ time over m arc additions, worst-case if s is always a median or approximate median of the set of choices, expected if s is always chosen uniformly at random.*

PROOF. Consider the addition of an arc (v, w) such that $f(v) > f(w)$. Each search step either traverses two arcs or deletes one or two loops. An arc can only become a loop once and be deleted once, so the extra time for such events is $O(m)$ over all arc additions. The arcs in Y were traversed by the search, so the time to form the new component and to reorder the vertices is $O(1)$ per arc traversal. The theorem follows from Theorem 6.3 and the proofs of Theorems 4.5 and 4.6. \square

To maintain strong components via topological search, we represent the graph of strong components by an adjacency matrix A with one row and one column per canonical vertex. If x and y are canonical vertices, $A(x, y) = 1$ if $x \neq y$ and there is an arc (q, r) with $f(q) = x$ and $f(r) = y$; otherwise, $A(x, y) = 0$. We represent the topological order of components by an explicit numbering of

the canonical vertices using consecutive integers starting from one. We also store the inverse of the numbering. If x is a canonical vertex, $position(x)$ is its number; if i is a vertex number, $vertex(i)$ is the canonical vertex with number i . Note that the matrix A is indexed by vertex, *not* by vertex number; the numbers change too often to allow indexing by number.

To maintain strong components via topological search, initialize all entries of A to zero. Add a new arc (v, w) by setting $A(f(v), f(w)) = 1$. If $f(v) > f(w)$, search forward from $f(w)$ and backward from $f(v)$ by executing $TOPOLOGICAL-SEARCH(f(v), f(w))$ where $TOPOLOGICAL-SEARCH$ is defined as in Section 5. Let k be the common value of i and j when the search stops. After the search, find the vertex set of the new component, if any, by running a linear-time static strong components algorithm on the graph whose vertex set is $X = F \cup B$ and whose arc set is $Y = \{(x, y) \mid x \text{ and } y \text{ are in } F \cup B \text{ and } A(x, y) = 1\}$. Whether or not there is a new component, reorder the old canonical vertices exactly as in Section 5. Finally, if there is a new component, do the following: form its vertex set by combining the vertex sets of the old components contained in it. Let the canonical vertex of the new component be $vertex(k)$. Form a row and column of A representing the arcs out of and into the new component by combining those of the old components contained in it. Delete from the topological order all the vertices that are no longer canonical. Number the remaining canonical vertices consecutively from 1.

Remark: As in soft-threshold search, using a static strong components algorithm to find the new component is overkill; a better method is the one described in the remark before Theorem 6.1: run a forward depth-first search from $f(w)$, marking vertices when they are found to be in the new component.

THEOREM 6.5. *Maintaining strong components via topological search is correct.*

PROOF. By induction on the number of arc additions. Consider the addition of an arc (v, w) . Let f and f' be the canonical vertex function just before and just after this addition, respectively. The addition creates a new component if and only if $f(v) > f(w)$ and there is a path from $f(w)$ to $f(v)$. Suppose $f(v) > f(w)$ and let F and B be the values of the corresponding variables just after the search stops. Any path from $f(w)$ to $f(v)$ consists of a sequence of one or more vertices in F followed by a sequence of one or more vertices in B . Each arc on such a path is in Y . It follows that the algorithm correctly finds the new component. If there is no new component, the algorithm reorders the vertices exactly as in Section 5 and thus restores topological order. Suppose there is a new component. Let k be the common value of i and j when the search stops. The reordering sets $vertex(k) = f(w)$. This vertex is the canonical vertex of the new component. Let (x, y) be an arc. The same argument as in the proof of Theorem 5.1 shows that $f'(x) = f(x) < f(y) = f'(y)$ after the reordering unless $f(x)$ or $f(y)$ or both are in the new component. If both are in the new component, then (x, y) is a loop after the addition of (v, w) . Suppose $f(x)$ but not $f(y)$ is in the new component. Then $f(x) \in F \cup B$. If $f(x) \in F$, then $position(f(y)) > k$ after the reordering but before the renumbering, so $f'(x) < f'(y)$ after the reordering and renumbering. If $f(x) \in B$, then $f(y) \notin B$, since otherwise $f(y)$ is in the component. It follows that $position(f(y)) > k$ before the reordering, and also after the reordering but before the renumbering, so $f'(x) < f'(y)$ after the reordering and renumbering. A symmetric argument applies if $f(y)$ but not $f(x)$ is in the new component. \square

THEOREM 6.6. *Maintaining strong components via topological search takes $O(n^{5/2})$ time over all arc additions.*

PROOF. The time spent combining rows and columns of A and renumbering vertices after deletion of non-canonical vertices is $O(n)$ per deleted vertex, totaling $O(n^2)$ time over all arc additions. The time spent to find the new component after a search is $O(|F| + |B|)^2 = O(|F||B|)$ since $|B| \leq |F| \leq |B| + 1$, where F and B are the values of the respective variables at the end of the search. If x is in F and y is in B , then either x and y are unrelated before the arc addition that triggered the search but related after it (and possibly in the same component), or they are related

and in different components before the arc addition but in the same component after it. A given pair of vertices can become related at most once and can be combined into one component at most once. There are $\binom{n}{2}$ vertex pairs. Combining these facts, we find that the total time spent to find new components is $O(n^2)$.

To bound the rest of the computation time, we apply Theorem 5.6. To do this, we modify the strong components algorithm so that it does not delete non-canonical vertices from the topological order but leaves them in place. Such vertices have no incident arcs and are never moved again. This only makes the search and reordering time longer, since the revised algorithm examines non-canonical vertices during search and reordering, whereas the original algorithm does not. The proof of Theorem 5.6 applies to the revised algorithm, giving a bound of $O(n^{5/2})$ on the time for search and reordering. \square

7. REMARKS

We are far from a complete understanding of the incremental topological ordering problem. Indeed, we do not even have a tight bound on the running time of topological search. Given the connection between this running time and the k -levels problem (see Section 5), getting a tighter bound seems a challenging problem. As mentioned in the introduction, Bender et al. [Bender et al. 2009] have proposed a completely different algorithm with a running time of $\Theta(n^2 \log n)$.

A more general problem is to find an algorithm that is efficient for any graph density. Our lower bound on the number of vertex reorderings is $\Omega(nm^{1/2})$ for any local algorithm (see the end of Section 4); we conjecture that there is an algorithm with a matching running time, to within a polylogarithmic factor. For sparse graphs, soft-threshold search achieves this bound to within a constant factor. For dense graphs, the algorithm of Bender, Fineman, and Gilbert achieves it to within a logarithmic factor. For graphs of intermediate density, nothing interesting is known.

We have used total running time to measure efficiency. An alternative is to use an incremental competitive model [Ramalingam and Reps 1991], in which the time spent to handle an arc addition is compared to the minimum work that must be done by any algorithm, given the same topological order and the same arc addition. The minimum work that must be done is the minimum number of vertices that must be reordered, which is the measure that Ramalingam and Reps used in their lower bound. (See the end of Section 4.) But no existing algorithm handles an arc addition in time polynomial in the minimum number of vertices that must be reordered. To obtain positive results, researchers have compared the performance of their algorithms to the minimum sum of degrees of reordered vertices [Alpern et al. 1990], or to a more-refined measure that counts out-degrees of forward vertices and in-degrees of backward vertices [Pearce and Kelly 2006]. For these models, appropriately balanced forms of ordered search are competitive to within a logarithmic factor [Alpern et al. 1990; Pearce and Kelly 2006]. In such a model, semi-ordered search is competitive to within a constant factor. We think, though, that these models are misleading: they ignore the possibility that different algorithms may maintain different topological orders, they do not account for the correlated effects of multiple arc additions, and good bounds have only been obtained for models that overcharge the adversary.

Alpern et al. [Alpern et al. 1990] and Pearce and Kelly [Pearce and Kelly 2007] studied batched arc additions as well as single ones. Pearce and Kelly give an algorithm that handles an addition of a batch of arcs in $O(m')$ time, where m' is the total number of arcs after the addition, and such that the total time for all arc additions is $O(nm)$. Thus on each batch the algorithm has the same time bound as a static algorithm, and the overall time bound is that of the incremental algorithm of Marchetti-Spaccamela et al. [Marchetti-Spaccamela et al. 1996].

This result is not surprising, because *any* incremental topological ordering algorithm can be modified so that each batch of arc additions takes $O(m')$ time but the overall running time increases by at most a constant factor. The idea is to run a static algorithm concurrently with the incremental algorithm, each maintaining its own topological order. Here are the details. The incremental algorithm maintains a set of added arcs that have not yet been processed. Initially this set is empty. To

handle a new batch of arcs, add them to the graph and to the set of arcs to be processed. Then start running a static algorithm; concurrently, resume the incremental algorithm on the expanded set of new arcs. The incremental algorithm deletes an arc at a time from this set and does the appropriate processing. Allocate time in equal amounts to the two algorithms. If the static algorithm stops before the incremental algorithm processes all the arcs, suspend the incremental algorithm and use the topological order computed by the static algorithm as the current order. If the incremental algorithm processes all the arcs, stop the static algorithm and use the topological order computed by the incremental algorithm as the current order. This algorithm runs a constant factor slower than the incremental algorithm and spends $O(m')$ time on each batch of arcs.

For the special case of soft-threshold search, this method can be improved to maintain a single topological order, and to restart the incremental algorithm each time the static algorithm completes first. The time bound remains the same. If the static algorithm stops first, replace the topological order maintained by the incremental algorithm by the new one computed by the static algorithm, and empty the set of new arcs. These arcs do not need to be processed by the incremental algorithm. This works because the running time analysis of soft-threshold search does not use the current topological order, only the current graph, specifically the number of related arc pairs. Whether something similar works for topological search is open. Much more interesting would be an overall time bound based on the size and number of batches that is an improvement for cases other than one batch of m arcs and m batches of single arcs.

Alpern et al. [Alpern et al. 1990] also allowed unrelated vertices to share a position in the order. More precisely, their algorithm maintains a numbering of the vertices such that if (v, w) is an arc, v has a lower number than w , but unrelated vertices may have the same number. This idea is exploited by Bender, Fineman, and Gilbert in their new algorithm.

ACKNOWLEDGMENTS

The last author thanks Deepak Ajwani, whose presentation at the 2007 Data Structures Workshop in Bertinoro motivated the work described in Section 4, and Uri Zwick, who pointed out the connection between the running time of topological search and the k -levels problem. All the authors thank the anonymous referees for their insightful suggestions that considerably improved the presentation.

REFERENCES

- AHO, A. V., HOPCROFT, J. E., AND ULLMAN, J. D. 1983. *Data Structures and Algorithms*. Addison Wesley.
- AJWANI, D. 2008. Traversing large graphs in realistic settings. Ph.D. thesis, Universität des Saarlandes, Saarbrücken, Germany.
- AJWANI, D., FRIEDRICH, T., AND MEYER, U. 2006. An $O(n^{2.75})$ algorithm for online topological ordering. In *Proc. 10th Scandinavian Workshop on Algorithm Theory (SWAT)*. 53–64.
- ALPERN, B., HOOVER, R., ROSEN, B. K., SWEENEY, P. F., AND ZADECK, F. K. 1990. Incremental evaluation of computational circuits. In *1st ACM-SIAM Symposium on Discrete Algorithms (SODA)*. 32–42.
- BELIK, F. 1990. An efficient deadlock avoidance technique. *IEEE Trans. on Comput.* 39, 7, 882–888.
- BENDER, M. A., COLE, R., DEMAINE, E. D., FARACH-COLTON, M., AND ZITO, J. 2002. Two simplified algorithms for maintaining order in a list. In *Proc. 10th European Symposium on Algorithms (ESA)*. 152–164.
- BENDER, M. A., FINEMAN, J. T., AND GILBERT, S. 2009. A new approach to incremental topological ordering. In *Proc. 20th ACM-SIAM Symposium on Discrete Algorithms (SODA)*. 1108–1115.
- BLUM, M., FLOYD, R. W., PRATT, V., RIVEST, R. L., AND TARJAN, R. E. 1973. Time bounds for selection. *J. Comput. Syst. Sci.* 7, 4, 448–461.
- CHERIYAN, J. AND MEHLHORN, K. 1996. Algorithms for dense graphs and networks on the random access computer. *Algorithmica* 15, 6, 521–549.
- DEY, T. K. 1998. Improved bounds for planar k -sets and related problems. *Discrete Comput. Geom.* 19, 3, 373–382.
- DIETZ, P. F. AND SLEATOR, D. D. 1987. Two algorithms for maintaining order in a list. In *Proc. 19th ACM Symposium on Theory of Computing (STOC)*. 365–372.
- DOR, D. AND ZWICK, U. 1999. Selecting the median. *SIAM J. Comput.* 28, 5, 1722–1758.
- GABOW, H. N. 2000. Path-based depth-first search for strong and biconnected components. *Information Processing Letters* 74, 3-4, 107–114.

- HAEUPLER, B., KAVITHA, T., MATHEW, R., SEN, S., AND TARJAN, R. E. 2008. Faster algorithms for incremental topological ordering. In *Proc. 35th International Colloquium on Automata, Languages and Programming (ICALP)*. 421–433.
- HAEUPLER, B., SEN, S., AND TARJAN, R. E. 2008. Incremental topological ordering and strong component maintenance.
- HAN, Y. AND THORUP, M. 2002. Integer sorting in $O(n\sqrt{\log \log n})$ expected time and linear space. In *Proc. 43rd IEEE Symposium on Foundations of Computer Science (FOCS)*. 135–144.
- HARARY, F., NORMAN, R. Z., AND CARTWRIGHT, D. 1965. *Structural Models : An Introduction to the Theory of Directed Graphs*. John Wiley & Sons.
- HOARE, C. A. R. 1961. Algorithm 65: Find. *Communications of the ACM* 4, 7, 321–322.
- KATRIEL, I. 2004. On algorithms for online topological ordering and sorting. Tech. Rep. MPI-I-2004-1-003, Max-Planck-Institut für Informatik, Saarbrücken, Germany.
- KATRIEL, I. AND BODLAENDER, H. L. 2006. Online topological ordering. *ACM Trans. on Algor.* 2, 3, 364–379.
- KAVITHA, T. AND MATHEW, R. 2007. Faster algorithms for online topological ordering.
- KNUTH, D. E. 1972. Mathematical analysis of algorithms. In *Proc. IFIP Congress*. 19–27.
- KNUTH, D. E. 1973. *The Art of Computer Programming, Volume 1: Fundamental Algorithms*. Addison-Wesley.
- KNUTH, D. E. AND SZWARCFITER, J. L. 1974. A structured program to generate all topological sorting arrangements. *Inf. Proc. Lett.* 2, 6, 153–157.
- LIU, H.-F. AND CHAO, K.-M. 2007. A tight analysis of the Katriel-Bodlaender algorithm for online topological ordering. *Theor. Comput. Sci.* 389, 1-2, 182–189.
- LIU, H.-F. AND CHAO, K.-M. 2008. An $\tilde{O}(n^{2.5})$ -time algorithm for online topological ordering.
- MARCHETTI-SPACCAMELA, A., NANNI, U., AND ROHNERT, H. 1993. On-line graph algorithms for incremental compilation. In *Proc. 19th International Workshop on Graph-Theoretic Concepts in Computer Science (WG)*. 70–86.
- MARCHETTI-SPACCAMELA, A., NANNI, U., AND ROHNERT, H. 1996. Maintaining a topological order under edge insertions. *Inf. Proc. Lett.* 59, 1, 53–58.
- NIVASCH, G. 2008. An improved, simple construction of many halving edges. In *Surveys on Discrete and Computational Geometry: Twenty Years Later*. AMS, 299–305.
- OMOHUNDRO, S. M., LIM, C.-C., AND BILMES, J. 1992. The Sather language compiler/debugger implementation. Tech. Rep. TR-92-017, International Computer Science Institute, Berkeley.
- PEARCE, D. J. 2005. Some directed graph algorithms and their application to pointer analysis. Ph.D. thesis, University of London, London, United Kingdom.
- PEARCE, D. J. AND KELLY, P. H. J. 2003. Online algorithms for topological order and strongly connected components.
- PEARCE, D. J. AND KELLY, P. H. J. 2006. A dynamic topological sort algorithm for directed acyclic graphs. *J. Exp. Algorithmics* 11, 1.7.
- PEARCE, D. J. AND KELLY, P. H. J. 2007. A dynamic batch algorithm for maintaining a topological order. Tech. rep., Victoria University, Wellington, New Zealand.
- PEARCE, D. J., KELLY, P. H. J., AND HANKIN, C. 2003. Online cycle detection and difference propagation for pointer analysis. In *Proc. IEEE Workshop on Source Code Analysis and Manipulation (SCAM)*. 3–12.
- RAMALINGAM, G. AND REPS, T. W. 1991. On the computational complexity of incremental algorithms. Tech. Rep. CS-TR-1991-1033, University of Wisconsin-Madison.
- RAMALINGAM, G. AND REPS, T. W. 1994. On competitive on-line algorithms for the dynamic priority-ordering problem. *Inf. Proc. Lett.* 51, 3, 155–161.
- RODITTY, L. AND ZWICK, U. 2008. Improved dynamic reachability algorithms for directed graphs. *SIAM J. Comput.* 37, 5, 1455–1471.
- SCHÖNHAGE, A., PATERSON, M., AND PIPPENGER, N. 1976. Finding the median. *J. Comput. Syst. Sci.* 13, 2, 184–199.
- SHARIR, M. 1981. A strong-connectivity algorithm and its applications in data flow analysis. *Comput. and Math. with App.* 7, 1, 67–72.
- SHARIR, M. AND SMORODINSKY, S. 2003. Extremal configurations and levels in pseudoline arrangements. In *Proc. 8th International Workshop on Algorithms and Data Structures (WADS)*. 127–139.
- SHMUELI, O. 1983. Dynamic cycle detection. *Information Processing Letters* 17, 4, 185–188.
- SZPILRAJN, E. 1930. Sur l’extension de l’ordre partiel. *Fund. Math.* 16, 386–389.
- TAMAKI, H. AND TOKUYAMA, T. 2003. A characterization of planar graphs by pseudo-line arrangements. *Algorithmica* 35, 3, 269–285.
- TARJAN, R. E. 1972. Depth-first search and linear graph algorithms. *SIAM J. Comput.* 1, 2, 146–160.
- TARJAN, R. E. 1975. Efficiency of a good but not linear set union algorithm. *J. ACM* 22, 2, 215–225.
- TARJAN, R. E. AND VAN LEEUWEN, J. 1984. Worst-case analysis of set union algorithms. *J. ACM* 31, 2, 245–281.

- THORUP, M. 2004. Integer priority queues with decrease key in constant time and the single source shortest paths problem. *J. Comput. Syst. Sci.* 69, 3, 330–353.
- TÓTH, G. 2001. Point sets with many k -sets. *Discrete Comput. Geom.* 26, 2, 187–194.
- VAN EMDE BOAS, P. 1977. Preserving order in a forest in less than logarithmic time and linear space. *Inf. Proc. Lett.* 6, 3, 80–82.
- VAN EMDE BOAS, P., KAAS, R., AND ZIJLSTRA, E. 1977. Design and implementation of an efficient priority queue. *Mathematical Systems Theory* 10, 99–127.
- ZWICK, U. 1986. Allowable circular sequences and their application (in Hebrew). M.S. thesis, Tel Aviv University, Tel Aviv, Israel.